

SLBS Engineering College Jodhpur

DEPARTMENT OF ELECTRICAL ENGINEERING

LAB- MANUAL

VIII SEM EE

HIGHVOLTAGE ENGINEERING LAB

8EE7

Experiment List

SEE7 HIGH VOLTAGE ENGINEERING LAB

1. Study filtration and Treatment of transformer oil.
2. Determine dielectric strength of transformer oil.
3. Study solid dielectrics used in power apparatus.
4. Study applications of insulating materials.
5. Study direct testing and indirect testing of circuit breakers.
6. Study high voltage testing of electrical equipment:
(i) Different line insulator (iii) cable (ii) bushing (iv) power capacitor
(v) power transformer.
7. Design an EHV transmission line.
8. Breakdown studies of uniform field and non-uniform field gaps under A.C. excitation:(i) Sphere to sphere (ii) Sphere to plane (iii) Sphere to point (iv) Plane to plane (v) Plane to Point (vi) Point to Point
9. To study of high voltage ac measurement.
10. Study the capacitance and dielectric loss measurement of an insulating material using Schering Bridge.

LAB ETHICS

DO's

- 1. Enter the lab on time and leave at proper time.**
- 2. Keep the bags outside in the racks.**
- 3. Utilize lab hours in the corresponding experiment.**
- 4. Make the Supply off the Kits/Equipments after completion of Experiments.**
- 5. Maintain the decorum of the lab.**

Don'ts

- 1. Don't bring any external material in the lab.**
- 2. Don't make noise in the lab.**
- 3. Don't bring the mobile in the lab.**
- 4. Don't enter in Faculty room without permission.**
- 5. Don't litter in the lab.**
- 6. Don't carry any lab equipments outside the lab**

We need your full support and cooperation for smooth functioning of the lab.

INSTRUCTIONS

BEFORE ENTERING IN THE LAB

- 1. All the students are supposed to prepare the theory regarding the present Experiment.**
- 2. Students are supposed to bring the practical file and the lab copy.**
- 3. Previous experiment should be written in the practical file.**
- 4. Object, Apparatus Table & Brief Theory of the current practical should be written in the lab copy.**
- 5. Any student not following these instructions will be denied entry in the lab and Sessional Marks will be affected.**

WHILE WORKING IN THE LAB

- 1. Adhere to experimental schedule as instructed by the faculty.**
- 2. Record the observations in lab copy & checked by the faculty**
- 3. Each student should work on his assigned table of the lab.**
- 4. Take responsibility of valuable accessories.**
- 5. Concentrate on the assigned practical and be careful.**
- 6. If anyone is caught red-handed carrying any equipment of the lab, then he will have to face serious consequences.**

EXPERIMENT NO.1

OBJECT:- Study filtration and Treatment of transformer oil.

Apparatus Required:- filtration and Treatment of transformer oil kit, Transformer oil.

THORY:-

Transformer Oil

Transformer oil is the most commonly used liquid dielectric in power apparatus. It is an almost colorless liquid consisting a mixture of hydrocarbons which include paraffin's, iso-paraffins, naphthalenes and aromatics. When in service, the liquid in a transformer is subjected to prolonged heating at high temperatures of about 950C, and consequently it undergoes a gradual ageing process. With time the oil becomes darker due to the formation of acids and resins, or sludge in the liquid. Some of the acids are corrosive to the solid insulating materials and metal parts in the transformer. Deposits of sludge on the transformer core, on the coils and inside the oil ducts reduce circulation of oil and thus its heat transfer capability gets considerably reduced. Complete specifications for the testing of transformer oils are given in IS 1866 (1983), IEC 296 (1969) and IEC 474 (1974)

TREATMENT OF TRANSFORMER OIL

Even though new synthetic materials with better mechanical and thermal properties are being developed, the use of oil/paper complex for high voltages is still finding applications. Oil, besides being a good insulating medium, it allows better dispersion of heat. It allows transfer and absorption of water, air and residues created by the ageing of the solid insulation. In order to achieve operational requirements, it must be treated to attain high degree of purity.

Whatever be the nature of impurities whether solid, liquid or gaseous, these bring down the dielectric strength of oil materially. Oil at 20°C with water contents of 44 ppm will have 25% of its normal dielectric strength. The presence of water in paper not only increases the loss angle $\tan \delta$, it accelerates the process of ageing. Similarly, air dissolved in oil produces a risk of forming bubble and reduces the dielectric strength of oil.

Air Absorption: The process of air absorption can be compared to a diffusing phenomenon in which a gaseous substance in this case air is in contact with liquid (oil here). If the viscosity of the liquid is low, the convection movements bring about a continuous intermixing whereby a uniform concentration is achieved.

This phenomenon can, for example, be checked in a tank where the air content or the water content measured both at the top and the bottom are approximately equal.

The absorption of air by oil can be given by the equation

$$\frac{dG}{dt} = p \cdot \frac{S}{V} [G_m - G(t)]$$

with boundary condition at $t = 0$ $G = G_0$

Solving the above equation

$$\frac{dG}{G_m - G(t)} = p \frac{S}{V} dt$$

or
$$\ln \{G_m - G(t)\} = -p \frac{S}{V} t + A$$

At $t = 0$ $G = G_0$. Therefore, $A = + \ln \{G_m - G_0\}$

or
$$\ln \frac{G_m - G(t)}{G_m - G_0} = -p \frac{S}{V} t$$

or
$$G_m - G(t) = (G_m - G_0) e^{-pSt/V}$$

Fig. 1.12 (a) shows the schematic for the measurement of air absorption by insulating oil which has previously been degassed as a function of the absorption time. The oil is degassed and dried with the help of the vacuum pump (1) and then introduced into the installation until the desired pressure is reached. A part of this air is absorbed by the oil, the pressure being maintained at a constant (2) Value by reducing the volume in absorption meter (3) Thus, air content of oil by volume can be measured. Precision manometer (4) is used to calibrate the absorption meter. Phosphorus pent oxide

trap (5) takes in the remainder of the water vapour.

In case of a completely degassed oil *i.e.*, at $t = 0$ $G = 0$, we obtain

$$G(t) = G_m (1 - e^{-pSt/V})$$

To have an estimate of air absorbed by oil, let us consider a hermetically sealed bushing impregnated under vacuum contains 20 litres of degassed oil ($G_0 = 0$). Suppose the bushing is opened at 25°C and remains under atmospheric pressure for 10 hours, the oil surface $S = 103 \text{ cm}^2$. Assume a typical value of $p = 0.4 \text{ cm/hr}$, the percentage of air absorbed is given as

$$G(10 \text{ hr}) = 10(1 - e^{-10^3/10^4 \times 0.4 \times 10})$$

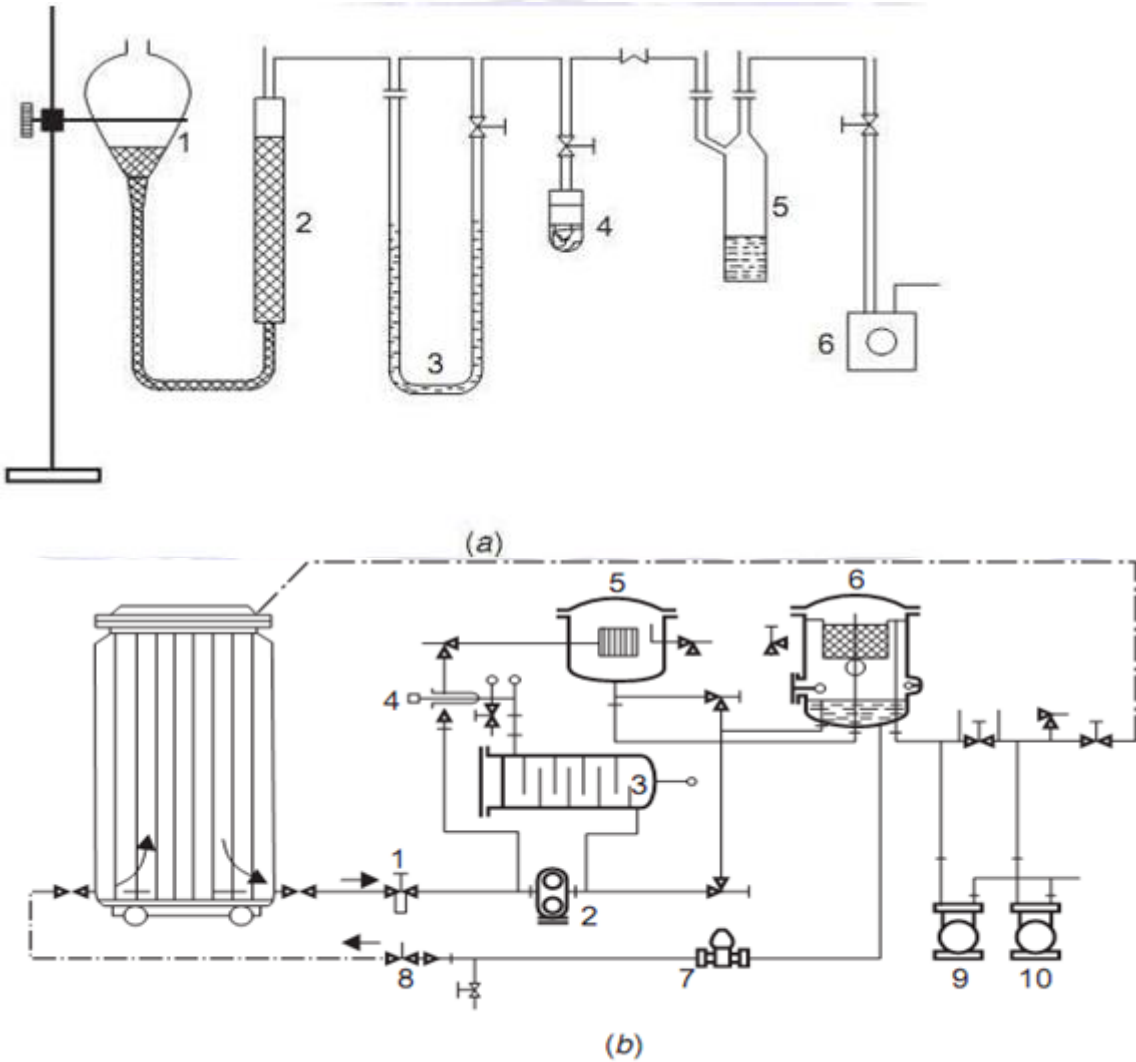

Fig. 1.12 (a), (b)

The molecules of oil are held together by their internal binding energy. In order that water molecule takes the place of oil molecule and is dissolved in the mixture, it is necessary to provide this molecule with a quantity of energy E in the form of heat.

Let N be the number of oil molecule n , the number of water molecules.

P_n the number of possibilities of combination for n water molecules among $(N + n)$ molecules.

i.e.,

S = Entropy of the oil

T = Absolute temperature of mixture $K =$

Boltzmann's constant

$E(T)$ = Energy required for a water molecule to take the place of an oil molecule $W =$

Water content of the oil (p.p.m.)

W_m = Maximum water content of the oil, at saturation point

Thermal equilibrium will be reached when free energy F is minimum i.e.,

$$\frac{\partial F}{\partial n} = 0$$

where
and

$$F = E(T) - TS$$

$$S = k \ln P_n$$

Now

$$\frac{\partial F}{\partial n} = \frac{\partial E(T)}{\partial n} - T \frac{\partial S}{\partial n} = 0$$

Since

$$P_n = \frac{(N+n)!}{N!n!}$$

Taking In both sides, we have

$$\begin{aligned} \ln P_n &= \ln(N+n)! - \ln N! - \ln n! \\ &= \ln(N+n) + \ln(N+n-1) + \ln(N+n-2) \\ &\quad \dots - \ln N! - \ln n - \ln(n-1) - \ln(n-2) - \ln(n-3) \end{aligned}$$

Differentiating both sides,

$$\begin{aligned} \frac{1}{P_n} \frac{\partial P_n}{\partial n} &= \frac{1}{N+n} + \frac{1}{N+n-1} + \dots - \frac{1}{n} - \frac{1}{n-1} \dots \\ &= \frac{1}{N+n} - \frac{1}{n} = -\frac{N}{n(N+n)} \end{aligned}$$

Since

$$\frac{\partial S}{\partial n} = \frac{K}{P_n} \frac{\partial P_n}{\partial n} = -\frac{KN}{n(N+n)}$$

Substituting for $\partial S/\partial n$ in the equation

$$\text{We have, } \frac{\partial E(T)}{\partial n} - T \frac{\partial S}{\partial n} = 0$$

$$\frac{\partial E(T)}{\partial n} + T \frac{TKN}{n(N+n)} = 0$$

or

$$\begin{aligned} \frac{\partial E}{\partial n} &= -\frac{TKN}{n(N+n)} \\ \partial E &= -TK \frac{N dn}{n(N+n)} \end{aligned}$$

Since

$$N \gg N+n \approx N$$

Therefore,

$$\partial E = -TK \frac{dn}{n}$$

or

$$E = -TK \ln n + A$$

when $E = 0$, $n = N$. Therefore, $0 = -TK \ln N + A$ or $A = TK \ln N$

OR

$$E = TK \ln \frac{N}{n}$$

OR

$$\ln \frac{n}{N} = -\frac{E}{TK} \quad \text{or} \quad \frac{n}{N} \approx e^{-E/TK}$$

OR

$$n = N e^{-E/TK} \approx W_m$$

Following impurities should be considered for purification of oil (i) solid impurities (ii) free and dissolved water particles (iii) dissolved air. Some of the methods used to remove these impurities have been described below.

Filtration and Treatment Under Vacuum: Different types of filters have been used. Filter press with soft and hard filter papers is found to be more suitable for insulating oil. Due to hygroscopic properties of the paper, oil is predried before filtering. Therefore, this oil can not be used for high voltage insulation. The subsequent process of drying is carried out in a specially, designed tank under vacuum. The oil is distributed over a large surface by a so-called __Rasching-ring““ degassing column. Through this process, both the complete drying and degassing are achieved simultaneously. By suitable selection of the various components of the plant e.g., rate of flow of oil, degassing surface, vacuum pump etc., a desired degree of purity can be obtained.

Fig. 1.12 (b) shows a typical plant for oil treatment. The oil from a transformer or a storage tank is prefiltered (1) so as to protect the feeder pump (2). In (3), the oil is heated up and is allowed to flow through filter press (4) into degassing tank (5). The degassing tank is evacuated by means of vacuum pump (6) whereas the second vacuum pump (7) is either connected with the degassing tank in parallel with pump (6) or can be used for evacuating the transformer tank which is to be treated.

The operating temperature depends upon the quality and the vapour pressure of oil. In order to prevent an excessive evaporation of the aromatics, the pressure should be greater than 0.1 Torr. The filtration should be carried out at a suitable temperature as a higher temperature will cause certain products of the ageing process to be dissolved again in the oil.

Centrifugal Method: This method is helpful in partially extracting solid impurities and free water. It is totally ineffective as far as removal of water and dissolved gases is concerned and oil treated in this manner is even over-saturated with air as air, is thoroughly mixed into it during the process. However, if the centrifugal device is kept in a tank kept under vacuum, partial improvement can be obtained. But the slight increase in efficiency of oil achieved is out of proportion to the additional costs involved.

Adsorption Columns: Here the oil is made to flow through one or several columns filled with an adsorbing agent either in the form of grains or powder. Following adsorbing agents have been used:

- (i) Fuller earth
- (ii) Silica gel
- (iii) Molecular sieves

Activated Fuller earths absorb carbonyl and hydroxyl groups which form the principal ageing products of oil and small amount of humidity. Best results of oil treatment are obtained by a combination of Fuller earth and subsequent drying under vacuum.

Silica gel and in particular molecular sieves whose pore diameter measures 4 \AA show a strong affinity for water. Molecular sieves are capable of adsorbing water 20% of its original weight at 25°C and water vapour pressure of 1 Torr whereas silica gel and Fuller earth take up 6 and 4 per cent respectively.

Molecular sieves are synthetically produced Zeolites which are activated by removal of the crystallization water. Their adsorption capacity remains constant up to saturation point. The construction of an oil drying plant using molecular sieves is, therefore, simple. The plant consists of an adsorption column containing the sieves and of an oil circulating pump.

The adsorption cycle is followed by a desorption cycle once the water content of the sieves has exceeded 20 per cent. It has been found that the two processes adsorption and desorption are readily reversible. In order to attain desorption of the sieves, it is sufficient to dry them in air stream of 200°C .

Electrostatic Filters: The oil to be treated is passed between the two electrodes placed in a container. The electrostatic field charges the impurities and traces of water which are then attracted and retained by the foam coated electrodes. This method of drying oil is found to be economical if the water content of the oil is less than 2 ppm. It is, therefore, essential that the oil is dried before hand if the water content is large. Also, it is desirable that the oil flow should be slow if efficient filtering is required. Therefore, for industrial application where large quantity of oil is to be filtered, large number of filters will have to be connected in parallel which may prove uneconomical.

Precaution:-

1. Transformer oil should be free from moisture content.
2. Gap should be premises.
3. Nobody should go near the H.T. bushing when the test being conducted.
4. Ignore the first one or two readings, as the air between the electrodes may not ionize.
5. The equipment must be grounded firmly.
6. The electrodes must be cleaned properly before and after the use.
7. Do not touch the equipment without grounding it with the grounding rod.
8. Before starting the experiment, make sure the electrodes are properly aligned and zero reading is adjusted.

Result:-

EXPERIMENT NO.2

OBJECT:- Determine dielectric strength of transformer oil.

Apparatus Required:-Transformer oil test kit, Transformer oil.

THORY:- The oil is poured in a container known as test-cell which has internal dimensions of 55 mm × 90 mm × 100 mm high. The electrodes are polished spheres of 12.7 to 13 mm diameter, preferably of brass, arranged horizontally with their axis not less than 40 mm above the bottom of the cell. For the test, the distance between the spheres shall be 4 + 0.02 mm. A suitable gauge is used to adjust the gap. While preparing the oil sample, the test-cell should be thoroughly cleaned and the moisture and suspended particles should be avoided. Fig. 1.13 shows an experimental set-up for finding out the dielectric strength of the given sample of oil. The voltmeter is connected on to the primary side of the high voltage transformer but calibrated on the high voltage side.

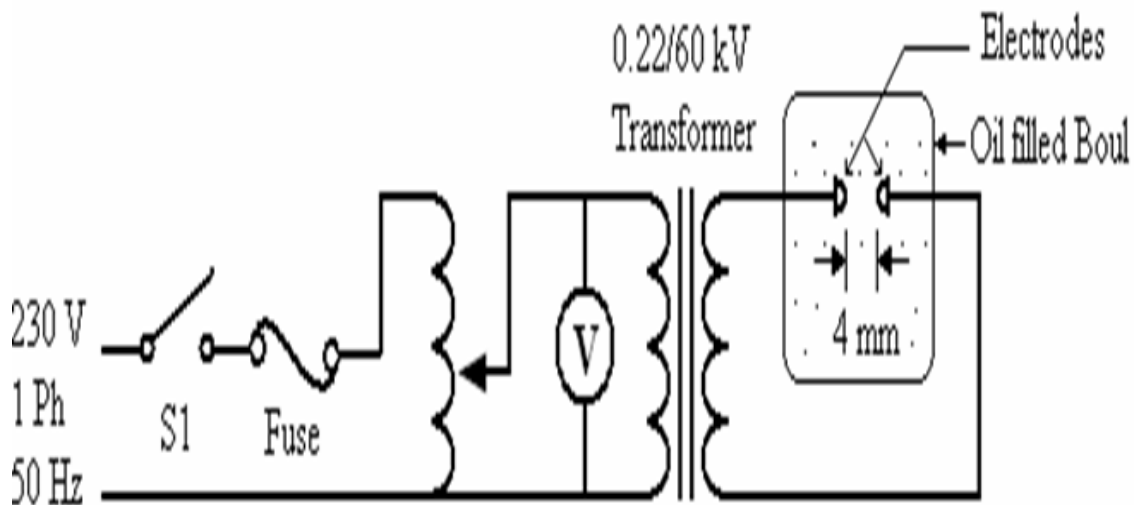

Fig. 1.13

The gap between the spheres is adjusted to 4 mm with the help of a gauge and the spheres are immersed in oil to a depth as mentioned earlier. The voltage is increased gradually and continuously till a flash over of the gap is seen or the MCB operates. Note down this voltage. This voltage is known as rapidly-applied voltage. The breakdown of the gap has taken place mainly due to field effect. The thermal effect is minimal as the time of application is short.

Next bring the voltage back to zero and start with 40% of the rapidly applied voltage and wait for one minute. See if the gap has broken. If not, increase the voltage every time by 2.1/2% of the rapidly applied voltage and wait for one minute till the flash over is seen or the MCB trips. Note down this voltage.

Start again with zero voltage and increase the voltage to a value just obtained in the previous step and wait for a minute. It is expected that the breakdown will take place. A few trials around this point will give us the breakdown value of the dielectric strength. The acceptable value is 30 kV for 4 mm applied for one minute. In fact these days transformer oils with 65 kV for 4 mm 1 minute value are available. If it is less than 30 kV, the oil should be sent for reconditioning. It is to be noted that if the electrodes are immersed vertically in the oil, the dielectric strength measured may turn out to be lower than what we obtained by placing the electrodes in horizontal position which is the normal configuration. It is due to the fact that when oil decomposes carbon particles being lighter rise up and if the electrodes are in vertical configuration, these will bridge the gap and the breakdown will take place at a relatively lower value.

Procedure:

1. Study the enclosed instructions on Transformer oil testing.
2. Switch on the test kit.
3. Slowly raise the voltage, and keep it at 30kV for one minute. At the end, record whether the oil sample withstood 30kV for one minute. If it fails earlier, note the time it stood, 30kV. If it fails at a voltage lower than 30kV, record that voltage as breakdown voltage.
4. Then raise the voltage till such time there is a break down, and record the breakdown voltage. All the time take care not to exceed the maximum voltage of 60kV.
5. Remove the suspended particles due to breakdown with the help of glass tube provided.
6. Wait for 5 minutes.
7. Repeat steps 3 to 6, five times given a total of six observations.
8. Switch off the test kit.

Precaution:-

1. Transformer oil should be free from moisture content.
2. Gap should be premises.
3. Nobody should go near the H.T. bushing when the test being conducted.
4. Ignore the first one or two readings, as the air between the electrodes may not ionize.
5. The equipment must be grounded firmly.
6. The electrodes must be cleaned properly before and after the use.
7. Do not touch the equipment without grounding it with the grounding rod.
8. Before starting the experiment, make sure the electrodes are properly aligned and zero reading is adjusted.

Result:-

EXPERIMENT NO.3

OBJECT:- Study solid dielectrics used in power apparatus.

THORY:-

Main requirements Solid Dielectrics Used in Power Apparatus

The main requirements of the insulating materials used for power apparatus are:

1. High insulation resistance
2. High dielectric strength
3. Good mechanical properties i.e., tenacity and elasticity
4. It should not be affected by chemicals around it
5. It should be non-hygroscopic because the dielectric strength of any material goes very much down with moisture content

Vulcanized rubber: Rubber in its natural form is highly insulating but it absorbs moisture readily and gets oxidized into a resinous material; thereby it loses insulating properties. When it is mixed with sulphur along with other carefully chosen ingredients and is subjected to a particular temperature it changes into vulcanized rubber which does not absorb moisture and has better insulating properties than even the pure rubber. It is elastic and resilient.

The electrical properties expected of rubber insulation are high breakdown strength and high insulation resistance. In fact the insulation strength of the vulcanized rubber is so good that for lower voltages the radial thickness is limited due to mechanical consideration.

The physical properties expected of rubber insulation are that the cable should withstand normal hazards of installation and it should give trouble-free service. Vulcanized rubber insulated cables are used for wiring of houses, buildings and factories for low-power work.

There are two main groups of synthetic rubber material:

- (i) general purpose synthetics which have rubber-like properties and
- (ii) Special purpose synthetics which have better properties than the rubber e.g., fire resisting and oil resisting properties.

The four main types are: (i) butyl rubber, (ii) silicon rubber, (iii) neoprene, and (iv) styrene rubber.

Butyl rubber: The processing of butyl rubber is similar to that of natural rubber but it is more difficult and its properties are comparable to those of natural rubber. The continuous temperature to which butyl rubber can be subjected is 85°C whereas for natural rubber it is 60°C. The current rating of butyl insulated cables is approximately same as those of paper or PVC insulated cables. Butyl

rubber compound can be so manufactured that it has low water absorption and offers interesting possibilities for a non-metallic sheathed cable suitable for direct burial in the ground.

Silicone rubber: It is a mechanically weak material and needs external protection but it has high heat resistant properties. It can be operated at temperatures of the order of 150°C. The raw materials used for the silicon rubber are sand, marsh gas, salt, coke and magnesium.

Neoprene: Neoprene is a polymerized chlorobutadiene. Chlorobutadiene is a colorless liquid which is polymerized into a solid varying from a pale yellow to a darkish brown color. Neoprene does not have good insulating properties and is used upto 660 V a.c. but it has very good fire resisting properties and therefore it is more useful as a sheathing material.

Styrene rubber: Styrene is used both for insulating and sheathing of cables. It has properties almost equal to the natural rubber.

Polyvinyl Chloride (PVC)

It is a polymer derived generally from acetylene and it can be produced in different grades depending upon the polymerization process. For use in cable industry the polymer must be compounded with a plasticizer which makes it plastic over a wide range of temperature. The grade of PVC depends upon the plasticizer. PVC is inferior to vulcanized in respect of elasticity and insulation resistance. PVC material has many grades.

General purpose type: It is used both for sheathing and as an insulating material. In this compound monomer plasticizers are used. It is to be noted that a V.R. insulated PVC sheathed cable is not good for use.

Hard grade PVC: These are manufactured with less amount of plasticizer as compared with general purpose type. Hard grade PVC is used for higher temperatures for short duration of time like in soldering and are better than the general purpose type. Hard grade can not be used for low continuous temperatures.

Heat resisting PVC: Because of the use of monomer plasticizer which volatilizes at temperature 80°C–100°C, general purpose type compounds become stiff. By using polymeric plasticizers it is possible to operate the material continuously around 100°C. PVC compounds are normally costlier than the rubber compounds and the polymeric plasticized compounds are more expensive than the monomer plasticized ones. PVC is inert to oxygen, oils, alkalis and acids and, therefore, if the environmental conditions are such that these things are present in the atmosphere, PVC is more useful than rubber.

Polythene

This material can be used for high frequency cables. This has been used to a limited extent for power cables also. The thermal dissipation properties are better than those of impregnated paper and the impulse strength compares favorably with an impregnated paper-insulated device. The maximum operating temperature of this material under short circuits is 100°C.

Cross-linked polythene: The use of polythene for cables has been limited by its low melting point. By cross-linking the molecules, in roughly the same way as vulcanizing rubber, a new material is produced which does not melt but carbonizes at 250 to 300°C. By using chemical process it has been made technically possible to cross-link polythene in conventional equipment for the manufacture of rubber. This is why the product is said to be -vulcanized or -cross-linked polythene. The polythene is inert to chemical reactions as it does not have double bonds and polar groups. Therefore, it was thought that polythene could be cross-linked only through special condition, e.g., by irradiating polythene with electrons, thereby it could be given properties of cross-linking such as change of tensile strength and better temperature stability. Many irradiation processes have been developed in the cable making industry even though large amounts of high energy radiations are required and the procedure is expensive.

Polythene can also be irradiated with ultraviolet light, after adding to it a small quantity of ultra violet sensitive material such as benzophenone. Under the influence of ultraviolet light on benzophenone, a radical is formed of the same type as in the decomposition of peroxide by the radical mechanism. Organic peroxides have also been used successfully to crosslink the polythene.

Impregnated paper

A suitable layer of the paper is lapped on the conductor depending upon the operating voltage. It is then dried by the combined application of heat and vacuum. This is carried out in a hermetically sealed steam heated chamber. The temperature is 120°–130°C before vacuum is created. After the device is dried, an insulating compound having the same temperature as that of the chamber is forced into the chamber. All the pores of the paper are completely filled with this compound. After impregnation the device is allowed to cool under the compound so that the void formation due to compound shrinkage is minimized.

In case of pre-impregnated type the papers are dried and impregnated before they are applied on the conductor. The compound used in case of impregnated paper is a semi fluid and when the cables are laid on gradients the fluid tends to move from higher to lower gradient. This reduces the compound content at higher gradients and may result in void formation at higher gradients. This is very serious for cables operating at voltages higher than 3.3 kV. In many cases, the failures of the cables have been due to the void formation at the higher levels or due to the bursting of the sheath at the lower levels because of the excessive internal pressure of the head of compound.

Insulating press boards. If the thickness of paper is 0.8 mm or more, it is called paper board. When many layers of paper are laminated with an adhesive to get desired thickness, these are known as press boards and are used in bushings, transformers as insulating barriers or supporting materials. The electrical properties of press boards varies depending upon the resin content. The application of these press boards depends upon the thickness and density of paper used. For high frequency capacitors and cables usually low density paper (0.8 gm/cm³) is used where medium density paper is used for power capacitors and high density papers are used in d.c. machines and energy storage capacitors. The electric strength of press board is higher than that of resins or porcelain. However, it is adversely affected by temperature above 20°C. The loss angle $\tan \delta$ also decreases with increase in temperature. The main advantage of this material is that it provides good mechanical support even at higher temperatures upto 120°C. Mica. Mica consists of crystalline mineral silicates of alumina and potash. It has high dielectric strength, low dielectric losses and good mechanical strength. All these properties make it useful for many electrical devices e.g., commutator segment separator, armature windings, electrical heating and cooling equipments and switchgear. Thin layers of mica are laminated with a suitable resin or varnish to make thick sheets of mica. Mica can be mixed with the required type of resin to obtain its application at different operating temperatures. Mica is used as a filler in insulating materials to improve their dielectric strength, reduce dielectric loss and improve heat resistance property.

Ceramics. Ceramics materials are produced from clay containing aluminum oxide and other inorganic materials. The thick parts of these substances is given the desired shape and form at room temperature and then baked at high temperature about (1450°C) to provide a solid inelastic final structure. Ceramics also known as porcelain in one of its forms have high mechanical strength and low permittivity ($\epsilon_r < 12$) are widely used for insulators and bushings. These have 40% to 50% of

clay, 30-20% of aluminum oxide and 30% of feldspar. The ceramics with higher permittivity ($\epsilon_r > 12$) are used in capacitors and transducers.

The specific insulation resistance of ceramics is comparatively low. The $\tan \delta$ of these materials is high and increases with increase in temperature resulting in higher dielectric loss. The breakdown strength of porcelain compared to other insulating material is low but it remains unaffected over a wide range of temperature variation. Porcelain is chemically inert to alkalis and acids and, therefore, corrosion resistant and does not get contaminated. Alumina (Al_2O_3) has replaced quartz because of its better thermal conductivity, insulating property and mechanical strength. It is used for the fabrication of high current vacuum circuit breakers.

Glass. Glass is a thermoplastic inorganic material consisting of silicon dioxide (SiO_2), which is available in nature in the form of quartz. Different types of metal oxides could be used for producing different types of glasses but for use in electrical engineering only non-alkaline glasses are suitable having alkaline content less than 0.8%. The dielectric constant of glass varies between 3.6 and 10.0 and the density varies between 2000 kg/m^3 and 6000 kg/m^3 . The loss angle $\tan \delta$ is less than 10^{-3} and losses are higher for lower frequencies. Its dielectric strength varies between 300 and 500 kV/mm and it decreases with increase in temperature. Glass is used for X-ray equipments, electronic valves, electric bulbs etc.

Epoxy Resins. Epoxy resins are low molecular but soluble thermosetting plastics which exhibit sufficient hardening quality in their molecules. The chemical cross-linking of epoxy resins is normally carried out at room temperatures either by a catalytic mechanism or by bridging across epoxy molecule through the epoxy or hydroxyl group. Epoxy resins have high dielectric and mechanical strength. They can be cast into desired shapes even at room temperature. They are highly elastic and it is found that when it is subjected to a pressure of 175000 psi, it returned to its original shape after the load is removed. The dielectric constant varies between 2.5 and 4.0. Epoxy resins basically being non-polar substances have high dc specific insulation resistance and low loss $\tan \delta$ compared to polar materials like PVC. However, when the temperature exceeds 100°C the specific insulation resistance begins to decrease considerably and $\tan \delta$ increases. Compared to porcelain the breakdown strength of epoxy resin is almost double at temperatures upto 100°C but decreases rapidly at higher temperatures.

As filler materials, the inorganic substances like quartz powder (SiO₂) are used for casting applications. In SF₆ gas insulated systems having epoxy resin spacers, aluminum oxide and also dolomite are used as filler materials. These are found to be more compatible to the decomposed products of SF₆ by partial discharge and arcing discharges.

It is to be noted that the cast or encapsulation should not contain voids or humidity especially in high voltage applications and the material is desired to be homogeneous. It is, therefore, desirable to dry and degas the individual components of the mixture and casting is preferably carried out in vacuum.

The epoxy resins casts are inert to ether, alcohol and benzol. However, most of them are soluble in mineral oils at about 70°C. It is for this reason that they are not found suitable for applications in filled transformers.

There are certain applications which require insulating materials to operate between a high ranges of temperature e.g., -270°C to 400°C. Some of the applications are space shuttle solar arrays, capacitors, transformers high speed locomotive, microprocessor chip carriers, cryogenic cables and other applications at cryogenic temperatures. For this some thermoplastic polymer films are used which have unique combination of electrical, mechanical and physical quantities and these materials are able to retain these properties over a wide range of temperatures where other insulating materials may fail.

Perfluoro carbon films have high dielectric strength very low dielectric constant of 2 and low dielectric loss of 2×10^{-4} at 100 Hz and 7.5×10^{-4} at 100 MHz. These films are used under extreme conditions of temperature and environment. These films are used for insulation on high temperature wires, cables, motor coils phase and ground insulation and for capacitors. This is also used as a substrate for flexible printed circuits and flexible cables.

Another insulating film in which has the best thermal properties in this category of insulating materials is polyimide film under the trade name of Kapton manufactured by DuPont of America. These films can be used between a very wide range of temperature variation varying between -270°C and 350°C. Its continuous temperature rating is 240°C. It has high dielectric and tensile strength. The disadvantages of the film are high moisture absorption rate and it is affected by alkalies and strong inorganic acids. Kepton films can be used capacitors, transformers formed coil insulation, motor state insulation and flexible printed circuits. The film is selectively costlier and is mainly used where its unique characteristics makes it the only suitable insulation. The use of this

insulation for motors reduces the overall dimensions of the motors for the same ratings. It is, therefore, used in almost all situations whose space is a serious problem and the other nature insulation result in bigger dimension.

Another recently developed resins is poly carbonate (PC) which is good heat resistant; it is flexible and has good dielectric characteristic. It is not affected by oils, fats and dilute acids but is adversely affected by alkalies, esters and aromatic hydrocarbons. The film being cost effective and fast resistant, it is used for coil insulation, slot insulation for motors and for capacitor insulation. This is known as the lexon polymer. General Electric Co. of USA has developed a film under the trade name Ultimo which is a poly ether mine (PEI) film which has dielectric strength comparable to that of polyimide film and has higher thermal conductivity and lower moisture absorption and is relatively less costlier. It is used as insulation for transformers and motors.

Result:-

EXPERIMENT NO.4

OBJECT:- Study applications of insulating materials.

THORY:-

Application of Insulating Materials

Insulating fluids (gases and liquids) provide insulation between phases and between phase and grounded parts of electrical equipments. These also carry out heat from the windings of the electrical equipments. However, solid insulating materials are used only to provide insulation only.

International Electro technical Commission has categories various insulating materials depending upon the temperature of operations of the equipments under the following categories.

Class Y 90°C Natural rubber, PVC, paper cotton, silk without impregnation.

Class A 105°C Same as class Y but impregnated

Class E 120°C Polyethylene, terephthalate, cellulose tricetrate, polyvinyl acetate enamel

Class B 130°C Bakelite, bituminised asbestos, fibre glass, mica, polyester enamel

Class F 155°C As class B but with epoxy based resin

Class H 180°C As class B with silicon resin binder silicone rubber, aromatic polyamide (nomex paper and fiber), polyimide film (enamel, varnish and film) and esteemed enamel

Class C Above 180°C, as class B but with suitable non-organic binders, teflon and other high temperature polymers.

While describing the dielectric and other properties of various insulating materials, their application for various electrical apparatus has also been mentioned in the previous paragraphs. However, a reverse process i.e., what insulating materials are used for a particular apparatus depending upon its ratings and environmental condition where the apparatus is required to operate, is also desirable and a brief review is given here.

Power Transformers. For small rating, the coils are made of super-enameled copper wire. For layer to layer, coil to coil and coil to ground (iron core) craft paper is used. However, for large size transformers paper or glass tape is rapped on the rectangular conductors whereas for coil to coil or coil to ground, insulation is provided using thick radial spacers made of press board or glass fiber.

In oil-filled transformers, the transformer oil is the main insulation. However between various layers of low voltage and high voltage winding oil-impregnated press boards are placed. SF₆ gas insulated power transformers make use of sheet aluminum conductors for windings and turn to turn insulation is provided by a polymer film. The transformer has annular cooling ducts through which SF₆ gas circulates for cooling the winding. SF₆ gas provides insulations to all major gaps in the transformer.

This transformer is used where oil filled transform is not suitable e.g., in cinema halls, high rise buildings and some especial circumstances: The end turns of a large power transformer are provided with extra insulation to avoid damage to coil when lightning or switching surges of high frequency are incident on the transformer winding.

The terminal bushings of large size power transformer are made of condenser type bushing. The terminal itself consists of a brass rod or tube which is wound with alternate layers of treated paper and tin foil, so proportioned, as to length, that the series of condensers formed by the tin foil cylinders and the intervening insulation have equal capacitances, thereby the dielectric stress is distributed uniformly.

Circuit Breakers. The basic construction of any circuit breaker requires the separation of contacts in an insulating fluid which serves two functions here:

- (i) It extinguishes the arc drawn between the contacts when the CB, opens.
- (ii) It provides adequate insulation between the contacts and from each contact to earth

Many insulating fluids are used for arc extinction and the fluid chosen depends upon the rating and type of C.B. The insulating fluids commonly used for circuit breakers are:

- (i) Air at atmospheric pressure: Air break circuit breaker upto 11 kV.
- (ii) Compressed air (Air blast circuit breaker between 220 kV and 400 kV)
- (iii) Mineral oil which produces hydrogen for arc extriction (transformer oil)
 - (a) Plain break oil, C.B. 11 kV–66 kV
 - (b) Controlled break oil C.B. or bulk oil C.B. between 66 kV–220 kV
 - (c) Minimum oil C.B. between 66 kV and 132 kV.
 - (iv) Ultra high vacuum C.B. upto 33 kV.
 - (v) SF₆ circuit breakers above 220 kV.

The controlled break and minimum oil circuit breakers enclose the breaker contacts in an arcing chamber made of insulating materials such as glass fibre reinforced synthetic resins etc. Rotating Machines. For low voltage a.c. and d.c. machines, the winding wire are super enameled wire and the other insulation used are vulcanized rubber and varnished cambric and paper. For high voltage and large power capacity machines, the space limitations demand the use of insulating materials having substantially greater dielectric strength. Mica is considered to be a good choice not only due to space requirements but because of its ability to withstand higher temperatures. However, the brittleness of mica makes it necessary to build up the required thickness by using thin flakes cemented together by varnish or bakelite generally with a backing of thin paper or cloth and then baking it under pressure.

Epoxy resin bounded mica paper is widely used for both low and high voltage machines. Multilayer slot insulation is made of press board and polyester film. However, for machines with high operating temperatures kapton polyimide is used for slot insulation. Mica has always been used for stator insulations.

In addition to mica, conducting non-woven polyesters are used for corona protection both inside and at the edges of the slots. Glass fibre reinforced epoxy wedge profiles are used to provide support between the winding bars, slots and the core laminations.

Power Cables. The various insulating materials used are vulcanized rubber, PVC, Polyethylene and impregnated papers. Vulcanised rubber, insulated cables are used for wiring of houses, buildings and factories for low power work. PVC is inert to oxygen, oils, alkalies and acids and therefore, if the environmental conditions are such that these things are present in the atmosphere, PVC is more useful than rubber. Polyethylene is used for high frequency cables. This has been used to a limited extent for power cables also. The thermal dissipation properties are better than those of impregnated paper. The maximum operating temperature of this cable under short circuits is 100°C. In case of impregnated paper, a suitable layer of the paper is lapped on the conductor depending upon the operating voltage. It is then dried by the combined application of heat and vacuum. The compound used in case of impregnated paper is semifluid and when the cables are laid on gradients the fluid tends to move from higher to lower gradients which reduces the compound content at higher gradients and may result in void formation at higher gradients. For this reason, impregnated paper cables are used upto 3.3 kV.

Following methods are used for elimination of void formation in the cables:

1. The use of low viscosity mineral oil for the impregnation of the dielectric and the inclusion of oil channels so that any tendency of void formation (due to cyclic heating and cooling of impregnate) is eliminated.
2. The use of inert gas at high pressure within the metal sheath and indirect contact with the dielectric.

Because of the good thermal characteristics and high dielectric strength of the gas SF₆, it is used for insulating the cables also. SF₆ gas insulated cables can be matched to overhead lines and can be operated corresponding to their surge impedance loading. These cables can be used for transporting thousands of MVA even at UHV, whereas the conventional cables are limited to 1000 MVA and 500 kV.

Power Capacitors. Capacitor design economics suggests the use of individual unit assembled in appropriate series and parallel connected groups to obtain the desired bank voltage and reactive power ratings both in shunt and series capacitor equipments. Series capacitor duty usually requires that a unit designated for a series application be more conservatively rated than a shunt unit. However, there is no basic difference in the construction of the two capacitors.

The most commonly used capacitor for the purpose is the impregnated paper capacitor. This consists of a pair of aluminium foil electrodes separated by a number of Kraft paper tissues which are

impregnated with chlorinated diphenyl and has a higher permittivity and results in reduction in the quantity of materials required for a given capacitance and the cost.

The working stress of an impregnated paper is 15 to 25 V/ μ and papers of thickness 6–12 μ are available and hence depending upon the operating voltage of the capacitor, a suitable thickness of the paper can be selected. Because of imperfection involved in the manufacturing process of the dielectric paper it is desirable to use at least two layers of tissues between metal foils so that the possibility of coincidence of weak spots is avoided.

The effective relative permittivity depends upon the paper and the impregnate. For chlorinated biphenyl impregnate the relative permittivity lies between 5 and 6. Normally through past experience, the area of the plate for a particular material of paper and impregnate per microfarad of capacitance is known and hence it is possible to obtain the number of turns of paper to be wound on a given diameter of mandrel for a specified foil width and for the particular lay-up of foil and paper.

The method of laying up the paper and metallic foil and the connection of lugs is shown in Fig. Two layers of dielectric are used as without it rolling would short circuit the plates. As a result of this, two capacitors in parallel are formed by the roll. The foil and the paper interleaved in this fashion are wound on to a mandrel which is split to allow easy removal of the finished roll. If the section of the container is same as that of the roll, minimum overall value for the capacitor is obtained. As a result of this, quantity of free impregnate is a minimum thereby the risk of leakage of impregnate with variation in temperature is reduced. Sometimes a high resistance (for discharge) is connected across the terminals of the capacitor for safety reasons.

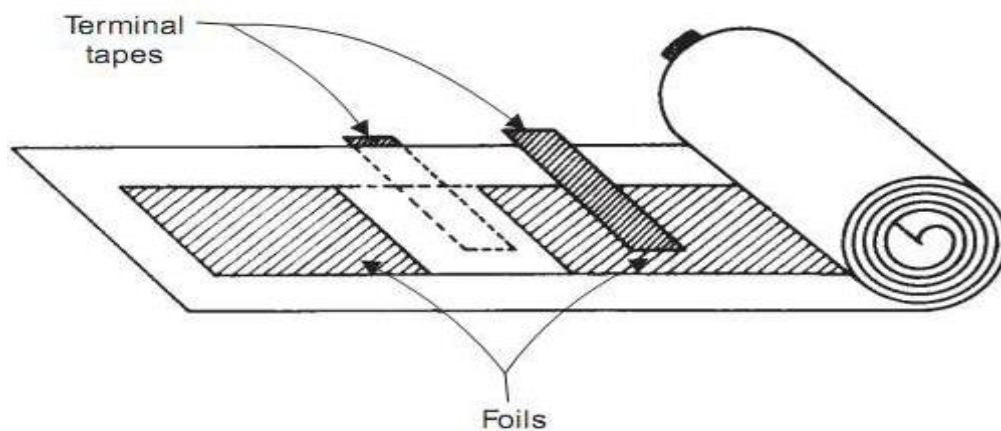

Fig. 1.20. Impregnated paper capacitor-terminal tape type

The replacement of linen by the Kraft paper and oil by askarel made it possible to have individual unit ratings upto 15 kVAr by 1930. After making some costly refinements in basic paper/askarel dielectric 100 kVAr rating capacitor were manufactured by 1960. General Electric Company designed a 150 kVAr unit using a paper/poly propylene film/askarel dielectric. Further advances in

the manufacture of dielectric materials led to single unit of 600 kVAr even though the rating of a single unit based on economy ranges between 200 and 300 kVAr. Replacement of askarel with non-PCB fluids did not have much effect on unit sizes or ratings. The newer all polypropylene film dielectric units offer distinct advantages in reduced losses and probability of case rupture as well as improvement in unit ratings. The large size units have made it possible to reduce the physical equipment size and the site area requirements.

With further development, it has now been possible to have series and shunt capacitor rating upto 550 kV and bank rating of upto 800 MVar. The average price of smaller units in terms of 100 kVAr is Rs. 100 per kVAr or \$2 per kVAr. It is to be noted that aluminium foil are used in these capacitors as it has high thermal and electrical conductivity, has high tensile strength, high melting point, is light in weight, low cost and is easily available.

Capacitor Bushings. Capacitor bushing is used for the terminals of high voltage transformers and switch gears. The power conductor is insulated from the flange by a capacitor bushing consisting of some dielectric material with metal foils cylindrical sheaths of different lengths and radii embedded in it as shown in Fig. 1.21 thus splitting up what essentially a capacitor having high voltage conductor and flange as it's plates, into a number of capacitors in series.

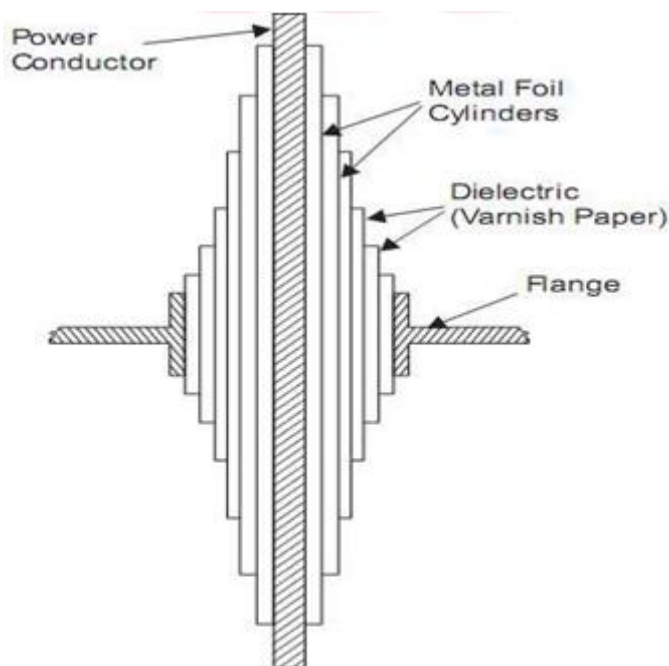

Fig. 1.21. Capacitor bushing

The capacitance of the capacitors formed by the metal foil cylinders is given by

$$C = \frac{\epsilon l}{2 \ln \frac{R_2}{R_1}}$$

where l is the axial length of the capacitor R_1 and R_2 are the radii of its cylindrical plates. If these capacitor have the same capacitance, the potential difference between their plates will be equal. The equal capacitance between different layers is made possible by choosing suitable axial length

together with ratio. With this strategy the potential gradient in the dielectric is uniform but the edges of the foil sheets lie on a curve, thus giving unequal surfaces of dielectric between the edges of successive sheets. This is undesirable as this would result into flashovers by -Creeping along the surface. However, if the differences between the lengths of successive sheets are made equal, the radial stress is not uniform and hence a compromise between the two conditions is usually adopted.

There are three types of papers used as insulating materials for capacitor bushings; oil impregnated paper, resin bonded paper and resin impregnated paper. The oil impregnated paper bushing is made by wrapping untreated paper after inserting foil sheets at the appropriate position and then impregnating with transformer oil after vacuum drying. Before impregnation, it is ensured that moisture and air voids are avoided. This bushing can work at a radial stress of 40 kV/cm.

In case of resin impregnated bushing creped paper tape is wrapped round the conductor and then dried in an autoclave under controlled heat and vacuum. Epoxyresin is then sprayed to fill the winding. The permissible radial stress in this case is 30 kV/cm.

In case of resin bonded paper bushing, the paper is first coated with epoxyresin and wrapped round a cylindrical form under heat and pressure after inserting foil sheets at appropriate position. The permissible radial stress in this case in 20 kV/cm.

Result:-

EXPERIMENT NO.5

OBJECT:-Study direct testing and indirect testing of circuit breakers.

APPARATUS REQUIRED:-Circuit Breaker kit, MCB & Fuse testing unit.

Technical specification:

Input voltage : 230 Vac.

Output current : 50A ac MAX. (Intermittent)

Output current ranges : 1A,2A,5A,10A,20A,50A

Zero current detector: $<300\text{ma}$

THORY:-

TESTING OF CIRCUIT BREAKERS

Equipment when designed to certain specification and is fabricated, needs testing for its performance. The general design is tried and the results of such tests conducted on one selected breaker and are thus applicable to all others of identical construction. These tests are called the type tests. These tests are classified as follows:

- (1) the dielectric tests or overvoltage tests,
- (2) the temperature rise tests,
- (3) the mechanical tests, and
- (Iv) the short circuit tests

Short Circuit Tests

The most important tests carried out on circuit breakers are short circuit tests, since these tests assess the primary performance of these devices, i.e. their ability to safely interrupt the fault currents. These tests consist of determining the making and breaking capacities at various load currents and rated voltages. In the case of isolators, the short circuit tests are conducted only with the limited purpose to determine their capacity to carry the rated short circuit current for a given duration; and no breaking or making current test is done.

The different methods of conducting short circuit tests are

- (I) Direct Tests
 - (a) using a short circuit generator as the source
 - (b) using the power utility system or network as the source.

(II) Synthetic Tests(Indirect test)

(a) Direct Testing in the Networks or in the Fields Circuit breakers are sometimes tested for their ability to make or break the circuit under normal load conditions or under short circuit conditions in the network itself. This is done during period of limited energy consumption or when the electrical energy is diverted to other sections of the network which are not connected to the circuit under test. The advantages of field tests are:

- (1) The circuit breaker is tested under actual conditions like those that occur in a given network.
- (2) Special occasions like breaking of charging currents of long lines, very short line faults, interruption of small inductive currents, etc. can be tested by direct testing only.
- (3) to assess the thermal and dynamics effects of short circuit currents, to study applications of safety devices, and to revise the performance test procedures,etc.

The disadvantages are:

- (1) The circuit breaker can be tested at only a given rated voltage and network capacity.
- (2) The necessity to interrupt the normal services and to test only at light load conditions.
- (3) Extra inconvenience and expenses in installation of controlling and measuring equipment in the field.

(b) Direct Testing in Short Circuit Test Laboratories In order to test the circuit breakers at different voltages and at different short circuit currents, short circuit laboratories are provided. The schematic layout of a short circuit testing laboratory is given in Fig. 10.3. It consists of a short circuit generator in association with a master circuit breaker, resistors, reactors and measuring devices. A make switch initiates the short circuit and the master circuit breaker isolates the test device from the source at the end of a predetermined time set on a test sequence controller. Also, the master circuit breaker can be tripped if the test device fails to operate properly. Short circuit generators with induction motors as prime movers are also available.

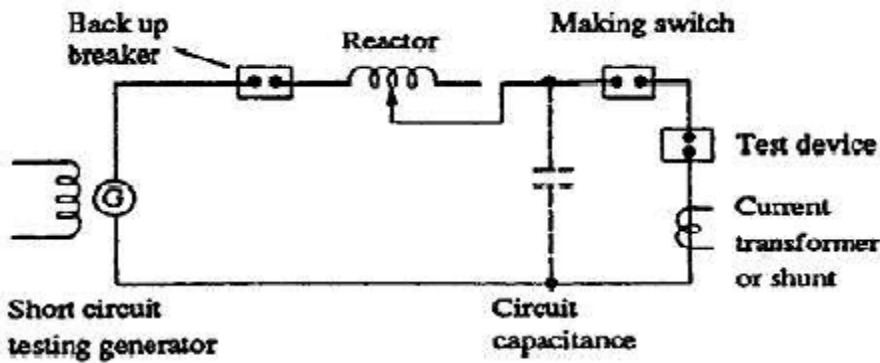

Fig. 10.3 Schematic diagram showing basic elements of a short circuit testing laboratory

(c) Synthetic Testing of Circuit Breakers Due to very high interrupting capacities of circuit breakers, it is not economical to have a single source to provide the required short circuit and the rated voltage. Hence, the effect of a short circuit is obtained as regards to the intensity of the current and the recovery voltage as a combination of the effects of two sources, one of which supplies the a.c. current and the other the high voltage.

In the initial period of the short circuit test, the a.c. current source supplies the heavy current at a low voltage, and then the recovery voltage is simulated by a source of comparatively high voltage of small current capacity. A schematic diagram of a synthetic testing station is shown in Fig.

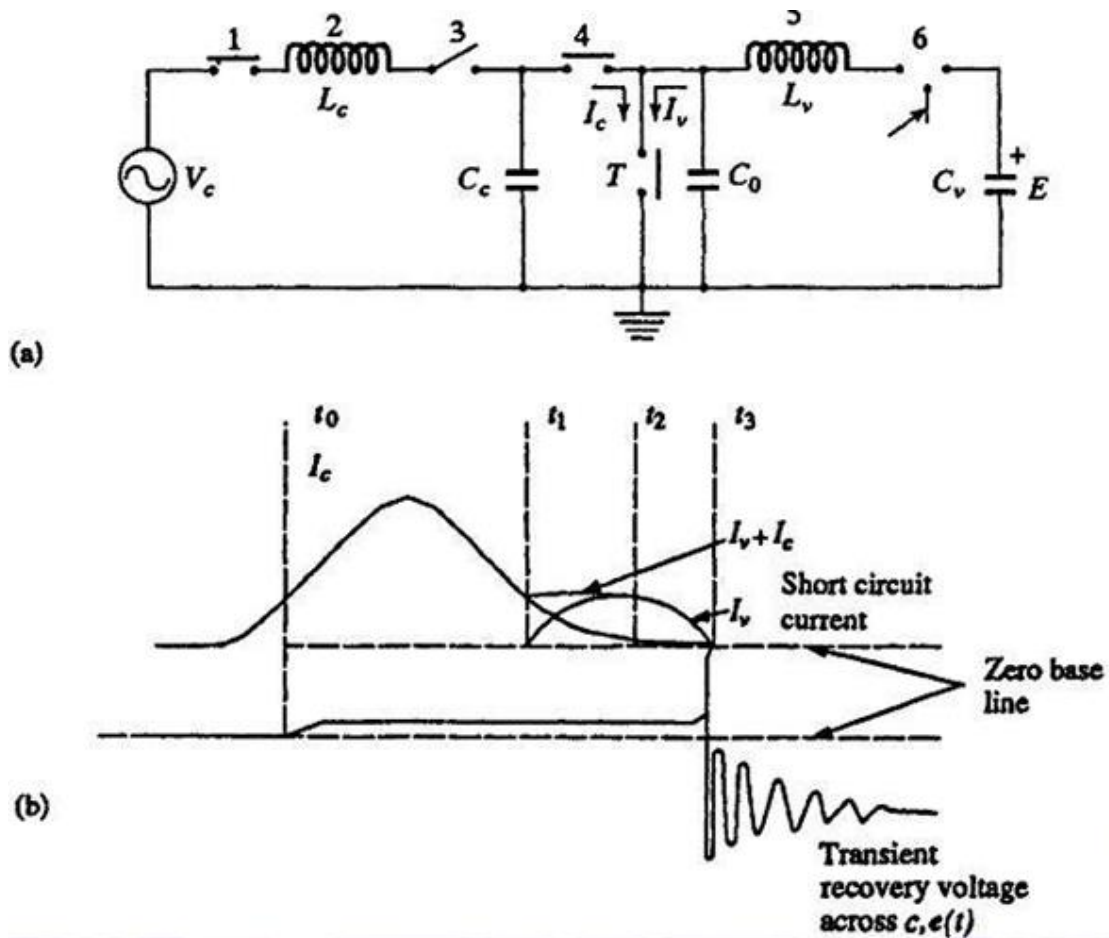

Fig. (a) Schematic diagram of synthetic testing of circuit breakers

(b) Current and recovery voltage waveforms across the test circuit breaker

With the auxiliary breaker (3) and the test breaker (T) closed, the closing of the making switch (1) causes the current to flow in the test circuit breaker. At some instant say to, the test circuit breaker (T) begins to operate and the master circuit breaker (1) becomes ready to clear the generator circuit. At some times t_1 , just before the zero of the generator current, the trigger gap (6) closes and the higher frequency current from the discharging capacitor C_v also flows through the arc. At time t_2 , when the generator current is zero, the circuit breaker (1) clears that circuit, leaving only the current from C_v which has the required rate of change of current at its zero flowing in the test circuit breaker. At the zero of this current/full test voltage will be available. The closing of gap (6) would be a little earlier in time than shown in Fig. 10.4, but it has been drawn as shown for clarity at current zeros. It is important to see that the high-current source is disconnected and a high-voltage source applied with absolute precision (by means of an auxiliary circuit breaker) at the instant of circuit breaking.

MCB TEST:-

INTRODUCTION

MCB & Fuse testing unit – 50A for to determine the characteristic of mcb & fuse wire constant length or constant current and also determine the fuse constant and fusing factor. Equipments can deliver 50A ac source.

Procedure:-

1. Connect as per interconnection diagram
2. connect the MCB
3. MCB is ON condition. (any one of the MCB)
4. Time interval meter selection switch in TIM position.
5. Connect the power card.
6. Bring dimmer to zero position.
7. Put on the mains using Mains on switch.(ROCKER). results (Mains on indicator, ammeter display and Timer display will glow.)
8. Select the current range, ranges available 1A,2A,5A,10A,25A,50A.
9. Short switch position in short conditions.
10. Push TEST START BUTTON
11. Adjust the dimmer ammeter shows current greater than approx 1.3 times the rated current of MCB.
12. Push TEST STOP/ RESET BUTTON.
13. Don't disturb the dimmer.
14. Bring the short switch in -OPEN| position.2
15. Push TEST START BUTTON .results ammeter shows the current, Time interval starts counting.
16. The time taken for the TRIP the MCB is noted.
17. Similarly repeat the above procedure for different values of current ratings of MCB / fuse wire and also for different lengths.
18. Plot the graphs.
19. **Note:** 1. please give some time to MCB cool after trip.
2. The equipment is short time and intermittent duty pure sine wave output wave

output.

Observation Table:-

No.	CB – 2A		CB – 4A		CB – 6A	
	ad current in ps	IP TIME	ad current in ps	IP TIME	ad current ps	IP TIME

CALCULATIONS

Minimum fusing current $I = K d^n \dots\dots\dots i$

Where K = fuse Constant
d = diameter of wire in mm
n = Prece’s constant = (3/2)
Take ln on both sides of equation (i)

$\ln I = \ln K + n \ln d$

therefore $n = (\ln I - \ln K) / \ln d$

The graph of $\ln I$ versus $\ln d$ is plotted and intercept on y axis (ordinate) gives value of K while slope $\tan\theta = (\ln I / \ln d)$ gives value of n

Minimum fusing current

Fusing factor = > 1

Rating current of fuse

Precautions:-

oil shou

1. Transformer should be free from moisture content.
2. Gap should be premises.
3. Nobody should go near the H.T. bushing when the test being conducted.
4. Ignore the first one or two readings, as the air between the electrodes may not ionize.
5. The equipment must be grounded firmly.
6. The electrodes must be cleaned properly before and after the use.
7. Do not touch the equipment without grounding it with the grounding rod.
8. Before starting the experiment, make sure the electrodes are properly aligned and zero reading is adjusted.

RESULTS:-The values of n,K and fusing factor are calculated

EXPERIMENT NO.6

OBJECT:-Study high voltage testing of electrical equipment: line insulator, cable, bushing, power capacitor, and power transformer.

Apparatus required: suspension, pin type insulator, transformer and cable.

THORY:-

Transmission at extra high voltages and the erection of systems which may extend over whole continents has become the most urgent problems to be solved in the near future. The very fast development of systems is followed by studies of equipment and the service conditions they have to fulfill. These conditions will also determine the values for testing at alternating, impulse and d.c. voltages under specific conditions.

TESTING OF OVERHEAD LINE INSULATORS

Various types of overhead line insulators are:

1. Pin type
2. Post type
3. String insulator unit
4. Suspension insulator string
5. Tension insulator.

Arrangement of Insulators for Test

String insulator unit should be hung by a suspension eye from an earthed metal cross arm. The test voltage is applied between the cross arm and the conductor hung vertically down from the metal part on the lower side of the insulator unit.

Suspension string with all its accessories as in service should be hung from an earthed metal cross arm. The length of the cross arm should be at least 1.5 times the length of the string being tested and should be at least equal to 0.9 m on either side of the axis of the string. No other earthed object should be nearer to the insulator string than 0.9 m or 1.5 times the length of the string whichever is greater. A conductor of actual size to be used in service or of diameter not less than 1 cm and length 1.5 times the length of the string is secured in the suspension clamp and should lie in a horizontal plane.

The test voltage is applied between the conductor and the cross arm and connection from the impulse generator is made with a length of wire to one end of the conductor. For higher operating voltages where the length of the string is large, it is advisable to sacrifice the length of the conductor as stipulated above. Instead, it is desirable to bend the ends of the conductor over in a large radius.

For tension insulators the arrangement is more or less same as in suspension insulator except that it should be held in an approximately horizontal position under a suitable tension (about 1000 Kg.).

For testing pin insulators or line post insulators, these should be mounted on the insulator pin or line post shank with which they are to be used in service. The pin or the shank should be fixed in a vertical position to a horizontal earthed metal cross arm situated 0.9 m above the floor of the laboratory. A conductor of 1 cm diameter is to be laid horizontally in the top groove of the insulator and secured by at least one turn of tie-wire, not less than 0.3 cm diameter in the tie-wire groove. The length of the wire should be at least 1.5 times the length of the insulator and should over hang the insulator at least 0.9 m on either side in a direction at right angles to the cross arm. The test voltage is applied to one end of the conductor.

High voltage testing of electrical equipment requires two types of tests: (i) Type tests, and (ii) Routine test. Type tests involves quality testing of equipment at the design and development level i.e. samples of the product are taken and are tested when a new product is being developed and designed or an old product is to be redesigned and developed whereas the routine tests are meant to check the quality of the individual test piece. This is carried out to ensure quality and reliability of individual test objects.

High voltage tests include (i) Power frequency tests and (ii) Impulse tests. These tests are carried out on all insulators.

- (i) 50% dry impulse flash over test.
- (ii) Impulse withstand test.
- (iii) Dry flash over and dry one minute test.
- (iv) Wet flash over and one minute rain test.
- (v) Temperature cycle test.
- (vi) Electro-mechanical test.
- (vii) Mechanical test.
- (viii) Porosity test.
- (ix) Puncture test.
- (x) Mechanical routine test.

The tests mentioned above are briefly described here.

(i) The test is carried out on a clean insulator mounted as in a normal working condition. An impulse voltage of $1/50 \mu$ sec. wave shape and of an amplitude which can cause 50% flash over of the insulator, is applied, i.e. of the impulses applied 50% of the impulses should cause flash over. The polarity of the impulse is then reversed and procedure repeated. There must be at least 20 applications of the impulse in each case and the insulator must not be damaged. The magnitude of the impulse voltage should not be less than that specified in standard specifications.

(ii) The insulator is subjected to standard impulse of $1/50 \mu$ sec. wave of specified value under dry conditions with both positive and negative polarities. If five consecutive applications do not cause any flash over or puncture, the insulator is deemed to have passed the impulse withstand test. If out of five, two applications cause flash over, the insulator is deemed to have failed the test.

(iii) Power frequency voltage is applied to the insulator and the voltage increased to the specified value and maintained for one minute. The voltage is then increased gradually until flash over occurs. The insulator is then flashed over at least four more times, the voltage is raised gradually to reach flash over in about 10 seconds. The mean of at least five consecutive flashes over voltages must not be less than the value specified in specifications.

(iv) If the test is carried out under artificial rain, it is called wet flash over test. The insulator is subjected to spray of water of following characteristics:

Precipitation rate $3 \pm 10\%$ mm/min.

Direction 45° to the vertical

Conductivity of water 100 micro siemens $\pm 10\%$

Temperature of water Ambient $+15^\circ\text{C}$

The insulator with 50% of the one-min. rain test voltage applied to it, is then sprayed for two minutes, the voltage raised to the one minute test voltage in approximately 10 sec. and maintained there for one minute. The voltage is then increased gradually till flash over occurs and the insulator is then flashed at least four more times, the time taken to reach flash over voltage being in each case about 10 sec. The flash over voltage must not be less than the value specified in specifications.

(v) The insulator is immersed in a hot water bath whose temperature is 70° higher than normal water bath for T minutes. It is then taken out and immediately immersed in normal water bath for T minutes. After T minutes the insulator is again immersed in hot water bath for T minutes. The cycle is repeated three times and it is expected that the insulator should withstand the test without damage to the insulator or glaze. Here $T = (15 + W/1.36)$ where W is the weight of the insulator in kgs.

(vi) The test is carried out only on suspension or tension type of insulator. The insulator is subjected to a $2\frac{1}{2}$ times the specified maximum working tension maintained for one minute. Also, simultaneously 75% of the dry flash over voltage is applied. The insulator should withstand this test without any damage.

(vii) This is a bending test applicable to pin type and line-post insulators. The insulator is subjected to a load three times the specified maximum breaking load for one minute. There should be no damage to the insulator and in case of post insulator the permanent set must be less than 1%. However, in case of post insulator, the load is then raised to three times and there should not be any damage to the insulator and its pin.

(viii) The insulator is broken and immersed in a 0.5% alcohol solution of fuchsin under a pressure of 13800 kN/m² for 24 hours. The broken insulator is taken out and further broken. It should not show any sign of impregnation.

(ix) An impulse over voltage is applied between the pin and the lead foil bound over the top and side grooves in case of pin type and post insulator and between the metal fittings in case of suspension type insulators. The voltage is 1/50 μ sec. wave with amplitude twice the 50% impulse flash over voltage and negative polarity. Twenty such applications are applied. The procedure is repeated for 2.5, 3, 3.5 times the 50% impulse flash over voltage and continued till the insulator is punctured. The insulator must not puncture if the voltage applied is equal to the one specified in the specification.

(x) The string in insulator is suspended vertically or horizontally and a tensile load 20% in excess of the maximum specified working load is applied for one minute and no damage to the string should occur.

Circuit Diagram:

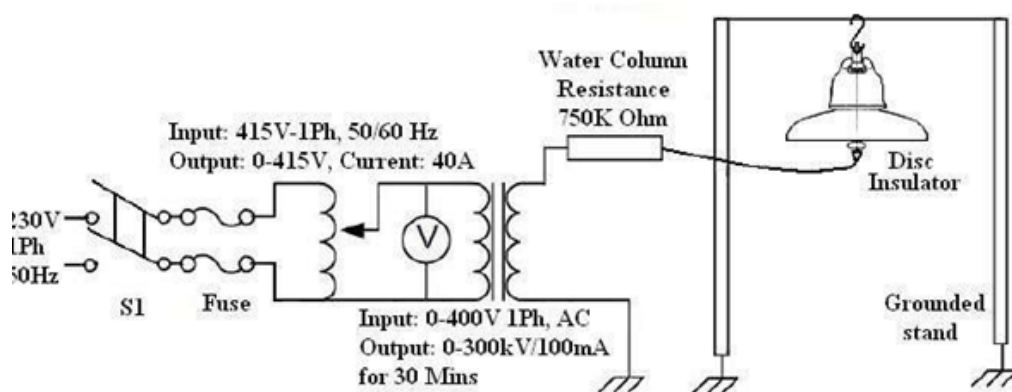

Procedure

1. Place the test frame (or stand) at suitable position.
2. Hang the disc with frame hanger as shown in circuit.
3. Clamping the GI ware clip at bottom of disc properly.
4. Complete the connection from HV transformer to ball pin of the disc insulator and earthed the frame properly with earth pit.
5. First, test the insulator at dry conditions (including correction factors) but at wet condition water arrangement should be checked as it works fine.
6. Close the Circuit Breaker S1.
7. Slowly raise the voltage till faint hissing sound is audible. This is the beginning of corona.
8. Slowly raise the voltage till such time that flashover at dry state is occurred. Reduce the voltage completely and open the CB.
9. Repeat the step 6 to 8 by increase the number of disc insulator.
10. Similarly, for wet test, first start the water shower at disc insulator(s) through nozzles. Then repeat the step from 6 to 9 and observed the values.

Disc specifications

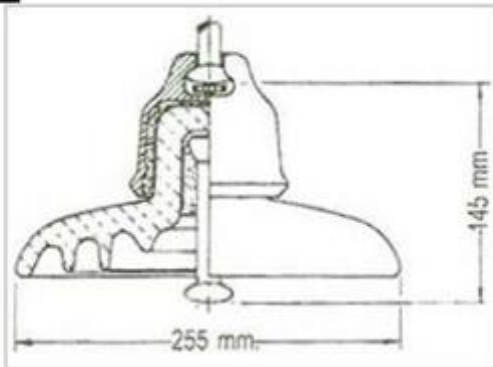

Product Specification

11 KV Disc Insulators (B&S type or T & C type)

Standard Particulars

Visible Discharge Voltage		9 kV
Porcelain Diameter		255 mm
Spacing		145 mm
Greepage Distance (Min.)		320 mm
Electro-mechanical Strength		70 KN
Flashover Voltage @ Power Frequency	Dry	65 kV
	Wet	45 kV
Impulse Flashover Voltage	+ ve	110 kV _p
	- ve	120 kV _p
Withstand Voltage @ Power Frequency 1 min.	Dry	50 kV
	Wet	35 kV
Impulse Withstand Voltage		
	+ve	75 kV _p
	-ve	80 kV _p
Puncture Voltage		105 kV
Net Weight (approx.)		5.0 Kgs.

TESTING OF CABLES

High voltage power cables have proved quite useful especially in case of HV d.c. transmission. Underground distribution using cables not only adds to the aesthetic looks of a metropolitan city but it provides better environments and more reliable supply to the consumers.

Preparation of Cable Sample

The cable sample has to be carefully prepared for performing various tests especially electrical tests. This is essential to avoid any excessive leakage or end flash overs which otherwise may occur during testing and hence may give wrong information regarding the quality of cables. The length of the

sample cable varies between 50 cms to 10 m. The terminations are usually made by shielding the ends of the cable with stress shields so as to relieve the ends from excessive high electrical stresses.

A cable is subjected to following tests:

- (i) Bending tests.
- (ii) Loading cycle test.
- (iii) Thermal stability test.
- (iv) Dielectric thermal resistance test.
- (v) Life expectancy test.
- (vi) Dielectric power factor test.
- (vii) Power frequency withstand voltage test.
- (viii) Impulse withstand voltage test.
- (ix) Partial discharge test.

(i) It is to be noted that a voltage test should be made before and after a bending test. The cable is bent round a cylinder of specified diameter to make one complete turn. It is then unwound and rewound in the opposite direction. The cycle is to be repeated three times.

(ii) A test loop, consisting of cable and its accessories is subjected to 20 load cycles with a minimum conductor temperature 5°C in excess of the design value and the cable is energized to 1.5 times the working voltage. The cable should not show any sign of damage.

(iii) After test as at (ii), the cable is energized with a voltage 1.5 times the working voltage for a cable of 132 kV rating (the multiplying factor decreases with increases in operating voltage) and the loading current is so adjusted that the temperature of the core of the cable is 5°C higher than its specified permissible temperature. The current should be maintained at this value for six hours.

(iv) The ratio of the temperature difference between the core and sheath of the cable and the heat flow from the cable gives the thermal resistance of the sample of the cable. It should be within the limits specified in the specifications.

(v) In order to estimate life of a cable, an accelerated life test is carried out by subjecting the cable to a voltage stress higher than the normal working stress. It has been observed that the relation between the expected life of the cable in hours and the voltage stress is given by

$$g = \frac{K}{n \sqrt{t}}$$

where K is a constant which depends on material and n is the life index depending again on the material.

(vi) High Voltage Schering Bridge is used to perform dielectric power factor test on the cable sample. The power factor is measured for different values of voltages e.g. 0.5, 1.0, 1.5 and 2.0 times the rated operating voltages. The maximum value of power factor at normal working voltage does not exceed a specified value (usually 0.01) at a series of temperatures ranging from 15°C to 65°C. The difference in the power factor between rated voltage and 1.5 times the rated voltage and the rated voltage and twice the rated voltage does not exceed a specified value. Sometimes the source is not able to supply charging current required by the test cable, a suitable choke in series with the test cable helps in tiding over the situation.

(vii) Cables are tested for power frequency a.c. and d.c. voltages. During manufacture the entire cable is passed through a higher voltage test and the rated voltage to check the continuity of the cable. As a routine test the cable is subjected to a voltage 2.5 times the working voltage for 10 min without damaging the insulation of the cable. HV d.c. of 1.8 times the rated d.c. voltage of negative polarity for 30 min. is applied and the cable is said to have withstood the test if no insulation failure takes place.

(viii) The test cable is subjected to 10 positive and 10 negative impulse voltage of magnitude as specified in specification, the cable should withstand 5 applications without any damage. Usually, after the impulse test, the power frequency dielectric power factor test is carried out to ensure that no failure occurred during the impulse test.

(ix) Partial discharge measurement of cables is very important as it gives an indication of expected life of the cable and it gives location of fault, if any, in the cable.

When a cable is subjected to high voltage and if there is a void in the cable, the void breaks down and a discharge takes place. As a result, there is a sudden dip in voltage in the form of an impulse. This impulse travels along the cable as explained in detail in Chapter VI. The duration between the normal pulse and the discharge pulse is measured on the oscilloscope and this distance gives the location of the void from the test end of the cable. However, the shape of the pulse gives the nature and intensity of the discharge.

In order to scan the entire length of the cable against voids or other imperfections, it is passed through a tube of insulating material filled with distilled water. Four electrodes, two at the end and two in the middle of the tube are arranged. The middle electrodes are located at a stipulated distance and these are energized with high voltage. The two end electrodes and cable conductor are grounded. As the cable is passed between the middle electrode, if a discharge is seen on the oscilloscope, a defect in this part of the cable is stipulated and hence this part of the cable is removed from the rest of the cable.

TESTING OF BUSHINGS

Bushings are an integral component of high voltage machines. A bushing is used to bring high voltage conductors through the grounded tank or body of the electrical equipment without excessive potential gradients between the conductor and the edge of the hole in the body. The bushing extends into the surface of the oil at one end and the other end is carried above the tank to a height sufficient to prevent breakdown due to surface leakage.

Following tests are carried out on bushings:

- (i) **Power Factor Test:** The bushing is installed as in service or immersed in oil. The high voltage terminal of the bushing is connected to high voltage terminal of the Schering Bridge and the tank or earth portion of the bushing is connected to the detector of the bridge. The capacitance and p.f. of the bushing is measured at different voltages as specified in the relevant specification and the capacitance and p.f. should be within the range specified.
- (ii) **Impulse Withstand Test:** The bushing is subjected to impulse waves of either polarity and magnitude as specified in the standard specification. Five consecutive full waves of standard wave form ($1/50 \mu \text{ sec.}$) are applied and if two of them cause flash over, the bushing is said to be defective. If only one flash over occurs, ten additional applications are made. If no flash over occurs, bushing is said to have passed the test.
- (iii) **Chopped Wave and Switching Surge Test:** Chopped wave and switching surge of appropriate duration tests are carried out on high voltage bushings. The procedure is identical to the one given in (ii) above.
- (iv) **Partial Discharge Test:** In order to determine whether there is deterioration or not of the insulation used in the bushing, this test is carried out. The procedure is explained in detail in Chapter-VI. The shape of the discharge is an indication of nature and severity of the defect in the bushing. This is considered to be a routine test for high voltage bushings.
- (v) **Visible Discharge Test at Power Frequency:** The test is carried out to ascertain whether the given bushing will give rise to ratio interference or not during operation. The test is carried out in a dark room. The voltage as specified is applied to the bushing (IS 2099). No discharge other than that from the grading rings or arcing horns should be visible.
- (vi) **Power Frequency Flash Over or Puncture Test (Under Oil):** The bushing is either immersed fully in oil or is installed as in service condition. This test is carried out to ascertain that the internal breakdown strength of the bushing is 15% more than the power frequency momentary dry withstand test value.

TESTING OF POWER CAPACITORS

Power capacitor is an integral part of the modern power system. These are used to control the voltage profile of the system. Following tests are carried out on shunt power capacitors (IS 2834):

(i) Routine Tests: Routine tests are carried out on all capacitors at the manufacturer's premises. During testing, the capacitors should not breakdown or behave abnormally or show any visible deterioration.

(ii) Test for Output: Ammeter and Voltmeter can be used to measure the kVAr and capacitance of the capacitor. The kVAr calculated should not differ by more than -5 to +10% of the specified value for capacitor units and 0 to 10% for capacitors banks.

The a.c. supply used for testing capacitor should have frequency between 40 Hz to 60 Hz, preferably as near as possible to the rated frequency and the harmonics should be minimum.

(iii) Test between Terminals: Every capacitor is subjected to one of the following two tests for 10 secs:

(a) D.C. test; the test voltage being $V_t = 4.3 V_0$

(b) A.C. test $V_t = 2.15 V_0$,

where V_0 is the rms value of the voltage between terminals which in the test connection gives the same dielectric stress in the capacitor element as the rated voltage V_n gives in normal service.

(iv) Test between Line Terminals and Container (For capacitor units): An a.c. voltage of value specified in column 2 of Table 5.1 is applied between the terminals (short circuited) of the capacitor unit and its container and is maintained for one minute, no damage to the capacitor should be observed. Figures with single star represent values corresponding to reduced insulation level (Effectively grounded system) and with double star full insulation level (non-effectively grounded system).

(v) IR Test: The insulation resistance of the test capacitor is measured with the help of a megger. The megger is connected between one terminal of the capacitor and the container. The test voltage shall be d.c. voltage not less than 500 volts and the acceptable value of IR is more than 50 megohms.

(vi) Test for efficiency of Discharge Device: In order to provide safety to personnel who would be working on the capacitors, it is desirable to connect very high resistance across the terminals of the capacitor so that they get discharged in about a few seconds after the supply is switched off. The residual capacitor voltage after the supply voltage is switched off should reduce to 50 volts in less than one minute of the capacitor is rated upto 650 volts and 5 minutes if the capacitor is rated for voltage more than 650 volts. A d.c. voltage $2 \times$ rms rated voltage of the capacitor is applied across the parallel combination of R and C where C is the capacitance of the capacitor under test and R is the high resistance connected across the capacitor. The supply is switched off and the fall in voltage across the capacitor as a function of time is recorded. If C is in microfarads and R in ohms, the time to discharge to 50 volts can be calculated from the formula

$$t = 2.3 \times 10^{-6} CR (\log_{10} V - 1.7) \text{ secs}$$

where V is the rated rms voltage of the capacitor in volts.

Type of Tests

The type tests are carried out only once by the manufacturer to prove that the design of capacitor complies with the design requirements:

(i) Dielectric Loss Angle Test (p.f. test)

High voltage schering bridge is used to measure dielectric power factor. The voltage applied is the rated voltage and at temperatures $27^{\circ}\text{C} \pm 2^{\circ}\text{C}$. The value of the loss angle $\tan \delta$ should not be more than 10% the value agreed to between the manufacturer and the purchaser and it should not exceed 0.0035 for mineral oil impregnates and 0.005 for chlorinated impregnates.

(ii) Test for Capacitor Loss

The capacitor loss includes the dielectric loss of the capacitor and the V^2/R loss in the discharge resistance which is permanently connected. The dielectric loss can be evaluated from the loss angle as obtained in the previous test and V^2/R loss can also be calculated. The total power loss should not be more than 10% of the value agreed to between the manufacturer and consumer.

(iii) Stability Test: The capacitor is placed in an enclosure whose temperature is maintained at $\pm 2^{\circ}\text{C}$ above the maximum working temperature for 48 hours. The loss angle is measured after 16 hours, 24 hours and 48 hours using High voltage Schering Bridge at rated frequency and at voltage 1.2 times the rated voltage. If the respective values of loss angle are $\tan \delta_1$, $\tan \delta_2$ and $\tan \delta_3$, these values should satisfy the following relations (anyone of them):

$$(a) \tan \delta_1 + \tan \delta_2 \leq 2 \tan \delta_2 < 2.1 \tan \delta_1$$

$$\text{or } (b) \tan \delta_1 \geq \tan \delta_2 \geq \tan \delta_3$$

(iv) Impulse voltage test between terminal and container

The capacitor is subjected to impulse voltage of $1/50\mu$ sec. Wave and magnitude as stipulated in column 3 of Table 5.1. Five impulses of either polarity should be applied between the terminals (joined together) and the container. It should withstand this voltage without causing any flash overs.

TESTING OF POWER TRANSFORMERS

Transformer is one of the most expensive and important equipment in power system. If it is not suitably designed its failure may cause a lengthy and costly outage. Therefore, it is very important to be cautious while designing its insulation, so that it can withstand transient over voltage both due to switching and lightning. The high voltage testing of transformers is, therefore, very important and would be discussed here. Other tests like temperature rise, short circuit, open circuit etc. are not considered here. However, these can be found in the relevant standard specification.

Partial Discharge Test

The test is carried out on the windings of the transformer to assess the magnitude of discharges. The transformer is connected as a test specimen similar to any other equipment as discussed in Chapter-VI and the discharge measurements are made. The location and severity of fault is ascertained using the travelling wave theory technique as explained in Chapter VI. The measurements are to be made at all the terminals of the transformer and it is estimated that if the apparent measured charge exceeds 104 picocoulombs, the discharge magnitude is considered to be severe and the transformer insulation should be so designed that the discharge measurement should be much below the value of 104 pico-coulombs.

Impulse Testing of Transformer

The impulse level of a transformer is determined by the breakdown voltage of its minor insulation (Insulation between turn and between windings), breakdown voltage of its major insulation (insulation between windings and tank) and the flash over voltage of its bushings or a combination of these. The impulse characteristics of internal insulation in a transformer differs from flash over in air in two main respects. Firstly the impulse ratio of the transformer insulation is higher (varies from 2.1 to 2.2) than that of bushing (1.5 for bushings, insulators etc.). Secondly, the impulse breakdown of transformer

insulation is practically constant and is independent of time of application of impulse voltage. Fig. 5.1 shows that after three micro seconds the flash over voltage is substantially constant. The voltage stress between the turns of the same winding and between different windings of the transformer depends upon the steepness of the surge wave front. The voltage stress may further get aggravated by the piling up action of the wave if the length of the surge wave is large. In fact, due to high steepness of the surge waves, the first few turns of the winding are overstressed and that is why the modern practice is to provide extra insulation to the first few turns of the winding. Fig. 5.2 shows the equivalent circuit of a transformer winding for impulse voltage.

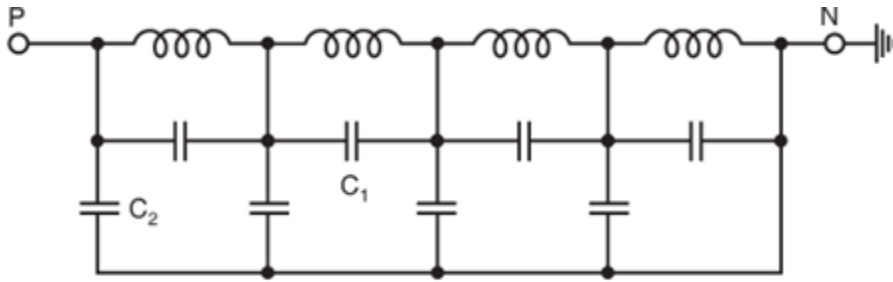

Fig. 5.2 Equivalent circuit of a transformer for impulse voltage

Here C1 represents inter-turn capacitance and C2 capacitance between winding and the ground (tank). In order that the minor insulation will be able to withstand the impulse voltage, the winding is subjected to chopped impulse wave of higher peak voltage than the full wave. This chopped wave is produced by flash over of a rod gap or bushing in parallel with the transformer insulation. The chopping time is usually 3 to 6 micro seconds. While impulse voltage is applied between one phase and ground, high voltages would be induced in the secondary of the transformer. To avoid this, the secondary windings are short-circuited and finally connected to ground. The short circuiting, however, decreases the impedance of the transformer and hence poses problem in adjusting the wave front and wave tail timings of wave. Also, the minimum value of the impulse capacitance required is given by

$$C_0 = \frac{P \times 10^8}{Z \times V^2} \mu\text{F}$$

where P = rated MVA of the transformer Z = per cent impedance of transformer. V = rated voltage of transformer.

Fig. 5.3 shows the arrangement of the transformer for impulse testing. CRO forms an integral part of the transformer impulse testing circuit. It is required to record to wave forms of the applied voltage and current through the winding under test.

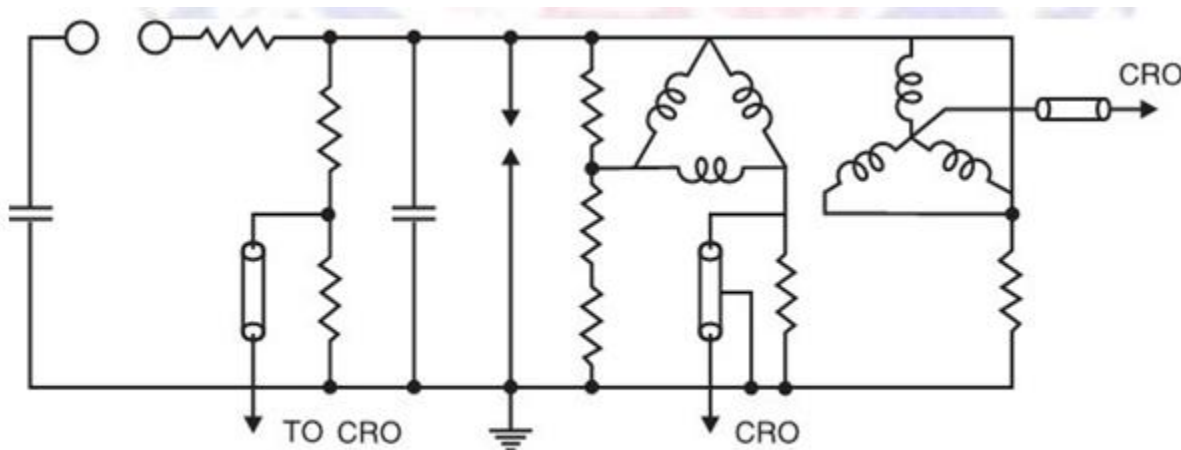

Fig. 5.3 Arrangement for impulse testing of transformer

Impulse testing consists of the following steps:

- (i) Application of impulse of magnitude 75% of the Basic Impulse Level (BIL) of the transformer under test.
- (ii) One full wave of 100% of BIL.
- (iii) Two chopped wave of 115% of BIL.
- (iv) One full wave of 100% BIL and
- (v) One full wave of 75% of BIL.

During impulse testing the fault can be located by general observation like noise in the tank or smoke or bubble in the breather. If there is a fault, it appears on the Oscilloscope as a partial of complete collapse of the applied voltage.

Study of the wave form of the neutral current also indicated the type of fault. If an arc occurs between the turns or from turn to the ground, a train of high frequency pulses are seen on the oscilloscope and wave shape of impulse changes. If it is a partial discharge only, high frequency oscillations are observed but no change in wave shape occurs. The bushing forms an important and integral part of transformer insulation. Therefore, its impulse flash over must be carefully investigated. The impulse strength of the transformer winding is same for either polarity of wave whereas the flash over voltage for bushing is different for different polarity. The manufacturer, however, while specifying the impulse strength of the transformer takes into consideration the overall impulse characteristic of the transformer.

Precautions:

1. Transformer oil should be free from moisture content.
2. Gap should be premises.
3. Nobody should go near the H.T. bushing when the test being conducted.
4. Ignore the first one or two readings, as the air between the electrodes may not ionize.
5. The equipment must be grounded firmly.
6. The electrodes must be cleaned properly before and after the use.
7. Do not touch the equipment without grounding it with the grounding rod.
8. Before starting the experiment, make sure the electrodes are properly aligned and zero reading is adjusted.

Result:

EXPERIMENT NO.7

OBJECT:- Design an EHV transmission line.

THORY:-

The transmission line Simulator with protection is designed to demonstrate the fault clearing process on transmission line using distance relay. The protection of transmission lines is usually done by distance protections schemes. The principle of operation of these relays depends on the ratio of voltage to current changes & is depends on the fault current and its power factor under the fault conditions. As a matter of fact such relays are designed to operate according to the impedance of the line upto the fault point or the ratio of voltage to current under fault condition. As the fault impedance is proportional to the distance of line, relay indicates the distance over which the fault has been occurred. The impedance relays known as distance relay.

A transmission line demo panel comprises a line model per phase basis having the length 400 KM & voltage of 220KV is designed for demonstration purposes. The lumped parameter line model with five cascaded networks each of them is designed for 80 KM parameters. Fault simulating switches are provided to create the fault condition. The switches are used to short live part of line to ground through some fault impedance at different locations. The impedance relay senses the fault current, voltage and gives trip signal to the circuit breaker if fault impedance is less than set value. The circuit breaker isolates the transmission lines from the supply.

The solid state impedance relay with single element is designed to measure the fault impedance with magnitude, compare it with set point value and give the trip signal to circuit breaker. The solid state over current Relay with single element is designed to measure the current in Transmission line. If current is more than set current value, relay gives trip signal to Circuit breaker.

The transmission line demo panel also comprises digital voltmeters, ammeters, push buttons, indicating lamps, hooter and accessories. A digital timer is used to measure time required for the detection & clearance of the fault.

The demo panel provided with protective devices i.e. MCB & HRC fuses to give protection from any abnormal condition occurring during the actual demonstration & experiments.

Specifications:

1. Panel Input supply : 1 Ph, 230V, 50Hz AC supply
2. Transmission line model. : Transmission line model for 400 km, 220KV transmission line with five π models cascaded each for 80 km line length having the lumped parameters.

 $R = 2 \Omega$, $C = 1\mu\text{F}$, $L = 25 \text{ mH}$.

Current capacity of model is 5 Amp.
3. Protective Relay
4. Solid state Impedance Relay : PT voltage=220V, CT current=1A, Aux. supply 230V AC.

CT Current 1A, over current range
Over Current Relay-up
BASED 0-5A settable ,
Aux. supply -230V AC
5. Panel Control Supply : 1-ph, 230V, 50Hz, AC supply.
6. Protection CT : a) SE CT 5/1A, 5 VA, class-1 - 2 no.
b) SE CT 10/1, 10VA class-1 – 3 no.
7. Switching Devices : a) 2 Pole, 6 A MCB for mains 2A for control
b) 3 Pole, 16 A, Power contactor ,Coil voltage 230V AC, as SE CB
c) 3 Pole, 16 A, Power contactor ,Coil Voltage 230V AC, as RE CB
8. Panel Protection : Over load & Short protection with 10A, DP M.C.B
9. Panel Indication and Push Buttons : a) Mains Indicating lamp (Green)
b) Fault indicating lamp (Red)
c) SE CB ON Push button (Red illumination)
d) SE CB OFF Push button (Red)

- e) RE CB ON Push Button (Red illumination)
- f) RE CB OFF Push Button (Red)
- g) Hooter audio fault annunciation
- h) Accept push button (yellow) & Reset Push button (red)

PVC terminals are provided on screen-printed front panel for transmission line model, Impedance relay, Current Transformer and load. The interconnection between protective CT & solid state impedance relay are done internally as per connection diagram. The 3 core x 1.5 sq. mm. Flexible copper cable is used for input supply connections. The earth terminals are provided on panel to connect permanent earth connection to panel after installation.

PANEL METERS

The digital panel meters are provided to measure Line voltage and Line current of transmission line at sending end and receiving end. The voltmeters are 0-300V, 3½ digits, 96 X 96 sq. mm. digital with 1-phase, 230V AC auxiliary supply. AC Ammeters are used to measure line currents at sending end and receiving end. The Ammeters are 0-5A, 3½ digits, 96 X 96 sq. mm. digital with 1-phase, 230V AC auxiliary supply. Power analyzers 96X96sqmm with 1-phase, 230V AC auxiliary supply.

DIGITAL TIMER

The 0 -199.999 seconds, 6 digit, 96 X 96 sq. mm. digital timer with 1-phase, 230V AC auxiliary supply is used to measure time delay required to clear the fault. The timer will start time counting on closing of any fault simulating switch and it will stop when protective relay operates & gives signal to open the circuit breakers.

ON-OFF SWITCHES & INDICATIONS

To switch on/off the input supply, 10A, DP MCB is used. A MAIN ON is indicated by green indicating lamp. Luminous push button PB1 is used to switch on the input contactor C1 [Sending end circuit breaker]. Push button PB2 is used to switch off the contactor C1. Red luminous push button PB5 [LOAD ON] is used to switch on output contactor C2 [Receiving end circuit breaker].

Push Button PB6 [Red] is used to switch OFF contactor C2 [for isolating load from transmission line]. The two pole, 10A, rotary switches are used as fault simulating switches. The switches SW1, SW2 and SW3 are used to simulate the phase to earth fault in transmission line at a distance 240 Km, 320 Km, 400 Km from sending end. RED indicating lamp indicates FAULT situation. When fault occurs, the relay sense the fault impedance and if fault impedance is less than set value, relay gives trip signal to circuit breaker control circuit & hooter gives audio alarm. Push buttons PB3 [Yellow] and PB4 [Red] are used to accept and reset the annunciation system.

TRANSMISSION LINE MODEL

Transmission line model is designed for 400 km, 220KV transmission line with five Π models cascaded each for 80 km line length having the lumped parameters. $R = 2\ \Omega$, $C = 1\ \mu\text{F}$, $L = 25\text{mH}$. Current capacity of model is 1 Amp. The transmission line model diagram is printed on front panel & terminals are provided for every π model so that the connections & checking is easily possible.

PROTECTIVE RELAY

A solid state Impedance relay is used to sense the fault impedance. The inputs from protection CT connected to relay Depending on fault current & voltage at sending end, the relay calculates the impedance. The digital display on relay gives percentage value of ratio of voltage & CT current (Percentage value of fault impedance). Under normal working condition the value of impedance is too high. But under the fault condition line current increases considerably high value & sending end voltage drops down slightly, so that the impedance value decreases suddenly. The value of percentage impedance will be 100% when CT secondary current is 1A and voltage is 220V.

When the PRESS TO SET button is pressed, the digital display will show the set point value of percentage impedance. The set point value of percentage impedance can be adjusted to any point (within range 0-180%) with set point pot by pressing the button. The solid state relay will be active, when percentage impedance sense by relay reduces less than set point value and relay will gives trip signal if fault condition remains for certain time delay. The time delay between activation of relay and tripping of relay will be inversely proportional to the difference between actual percentage impedance sense by relay and set value of percentage impedance. As the difference is very high relay will trip fast after activation. The impedance relay works on single phase, 230V AC auxiliary supply. The relay can be designed to operate on 110V AC supply.

PROTECTION CURRENT TRANSFORMER

The wound primary, round core current transformer at sending end of transmission line is sense the sending current of line. The sending end current transformers are 5/1A, 5 VA. The signals from CT connected to impedance relay.

LOADS

Loads are in built with the panel. RLC variable load is fitted inside the panel.

Resistive load is variable pot of 0-50 Ω and 100watts. Three pots are provided.

Inductive load is also variable with the help of selector switch this can be varied in steps of 2.5, 5, 10 μ Henries. Maximum of 5A current capacity three inductors are provided .

Capacitive load is fixed 10 μ F capacitors are fitted inside. three capacitors can be turned on or off with the help of three selector switches.

Procedure:-

- Connect mains cable to 230V, single phase, AC supply with proper earth connection.
- Keep SW1, SW2, SW3, MCB and all switches OFF position.
- Switch on input MCB. Check MAINS ON indication and voltage at sending end is displayed on input side digital voltmeter.
- Check impedance relay supply & its DPM should be ON indicating maximum value of Impedance.
- Check the over current relay, & its DPM should indicate minimum value of current.
- Press push button PB1, sending end contactor (C1) gets energized & gives on Indication and the supply is connected to line model.
- Press Push Button PB5, contactor C2 gets energized & gives LOAD ON indication and Load gets connected to transmission line model. Voltage and current at load end and current at sending end is displayed. Adjust sending end current about 1 Ampere.
- Adjust set value of impedance on solid state relay. Note down set point value of Percentage impedance.
- Adjust the Set value of over current relay. Note down the set point value of set current.

- Create the phase to earth fault with the help of SW1, SW2 and SW3 one by one starting from switch SW3.
- When the fault is created, impedance relay will calculate percentage fault impedance & it will be displayed on relay DPM. Note down percentage fault impedance. If fault Impedance is less than set point value, the relay ACTIVE indication will be ON. If Fault current is more than set value of over current relay, Relay will Active & give Active indication ON.
- The timer will start time counting, if fault condition remains for specific time delay the FAULT indication is ON & relay gives trip signal to circuit breaker control circuit.
- The trip circuit energizes contactor A1 and also to hooter coil. Hooter gives an audio alarm. The contactor C1 is de-energized and line is opened from supply.
- Repeat the procedure with different fault locations with different set point values and find the impedance relay response.

TRANSMISSION LINE MODEL 400KM

Line voltage assumed = 220v = 220kva

Sending end transformer = 1kva

Sending end current = 4.54A

So full load current = 4.54A

Total Impedance of transmission line = $220\text{v}/4.5\text{A} = 48.9\Omega$

Total no of section = 5

Now for each section = $48.9/5 = 9.78 \Omega$

$$X_L = 2\pi fL$$

$$9.78\Omega = 2\pi fL$$

$$L = 31\text{mH}$$

Taking L= 25 mH

Now indicator value for each section = 25mH

As per standard R= 0.0312 (0.031 Ω /Km)

As 1 st section = $400/5 = 80\text{Km}$

R for each section = $80 \times 0.0312 \Omega = 2.496 \Omega$

Taking $R=2\ \Omega$ & capacitor $C=15 \times 10^{-9} \times 80 = 1.2\ \mu\text{F} = 1\ \mu\text{F}$

Relay setting range : 0 – 200%

PT = 220v

CT = 4.5 = 5A , $220/5\text{A} = 44\ \Omega$

Fault switches are off – sw1, sw2 & sw3

Adjust 220v at SE

Connect upto 1 A load at RE

Now s/w on sw3 with at 100% distance – 400km

Sw3 line = $R=2\ \text{Ohms}$, $L=25\text{mH}$, $C=1\ \mu\text{F}$

Therefore = 9.78 ohms per section x 5 section = 48.9 Ohms

400km = 4.89 A = 100%

Switch 3 is

9.78ohms x 5 section = 48.9 ohms

$220\text{v}/4.5\ \text{Ohms} = 4.89\text{A}$

$(220/4.54\text{A})/48.9 \times 100 = 100\%$ impedance

Sw2

9.78ohms x 4 section = 39.12Ohms

Per section is 80km x 4 = 320kms

Therefore

$220\text{v} / 39.12\text{Ohms} = 5.6\text{A}$

$((220/5.6)/48.9) \times 100 = 80\%$ impedance

Sw1 at section 3

9.78 Ohms x 3 = 29.01Ohms

Line $220/29.01\ \text{Ohms} = 7.5\text{A}$

Line current is 7.5 A, So

% is $220/7.5/48.9 \times 100 = 60\%$ impedance

OVER CURRENT PROTECTION

Switch off Impedance relay.

Set $V =$ at sending end $= 220\text{v}$

Set I on O/C relay $= 2\text{A}$ (0-5A)

Keep t at max.

Connect load 1 amp.

Increase the load above 2A- 2.5A

Relay will get active & trip.

Time measure approx. 10sec.

Then 3A load- time will be approx.7 sec

Then 4A load – measure the trip time

If the load increases trip time will be less (inverse characteristic)

Transmission model with RLC loading.

Switch off OC relay & Impedance relay.

Adjust sending end voltage $=220\text{v}$

Connect resistive load of 1 -2 A

Now measure receiving end voltage and current.

R & L with series connect and observe.

R & L series and across connect capacitance and observe , note down the readings.

Resistive load.

Voltage is $220\text{v}/4.5\text{A}=48.4\text{Ohms}$

$Z=48.4$ ohms for 400km/5 section

400km/5section = 80km per section.

48.9 ohms/5section = each section is 9.78 Ohms.

Therefore , $9.78 \times 4.54\text{A} = 44.4\text{V}$ across each section.

Voltage at 80km $= 220\text{v}-(\text{voltage drop})$

$$V \text{ drop} = Z \times I$$

$$= 9.78 \times 4.54 = 44.4 \text{ V AT 80KM}$$

$$\text{AT 160KM} = 134\text{V}$$

$$\text{AT 240KM} = 88.8\text{V}$$

$$\text{AT 320KM} = 44.4\text{V}$$

$$\text{AT 400KM} = 0\text{V}$$

Load Unit.

L = 2.5,5,10mH , 5 Amp. Capacity – 3 nos.

C= 10uf /440V – 3 nos.

R = 0-50 Ohms – 3 nos.

MEASUREMENTS OF ABCD CONSTANTS OF A TRANSMISSION LINE

Objective:

1. To determine the ABCD constants, characteristic impedance and propagation constant
2. To determine the Ferranti effect on no load
3. To determine the reactive power required for zero regulation at different loads.

Introduction:

Long lines cause special problems in power systems. The voltage at the receiving end may rise, on no load or light load, beyond permissible limits; but on load the voltage may drop below normal. The phase shift may become excessively large and lead to stability problems. The no-load current may be large, if not compensated, and introduce some of the problems associated with long lines.

Theory:

Since a transmission line is symmetrical, the measurement of the open circuit and short circuit impedances is enough to determine the ABCD constants.

Open - circuiting the load end of the line, the open circuit impedance is measured at the sending end as

$$Z_{oc} = A/C \quad (1)$$

Short circuiting the load end of the line, the short circuit impedance Z_{sc} is measured at the sending end as

$$Z_{sc} = B/A \quad (2)$$

For a symmetrical network,

$$A = D \quad (3)$$

For a passive network,

$$AD - BC = 1 \quad (4)$$

Substituting equation (3) in equation (4),

Substituting equation (3) in equation (4),

$$A^2 - BC = 1 \quad (5)$$

Using equations (1)-(5), we get

$$A = \frac{Z_{oc}}{Z_{sc}} \quad (6)$$

$$B = A \cdot Z_{sc} \quad (7)$$

$$C = A/Z_{oc} \quad (8)$$

Note that all parameters A, B, C, D and the measured quantities Z_{oc} and Z_{sc} are complex numbers

Part I:

1. Connect the transmission line input terminal to transformer output terminals open receiving end.
2. Apply 220 V or less to measure Z_{oc}

$$Z_{oc} = \frac{V_s}{I_s} \quad (9)$$

$$Z_{oc} = V_s/I_s \quad (10)$$

$$\cos \theta = W_s/(V_s I_s) \quad (11)$$

Calculate Z_{oc} as a phasor.

3. For measuring Z_{sc} , short circuit receiving end with the help of switch 3 pass a current of 4.5A or less Calculate

Z_{sc} as phasor from equations similar to (9)-(11).

4. Calculate ABCD constants as phasors from equations (6)-(8).

5. Determine the surge impedance Z_0 and propagation constant λl as phasors from the following equations;

(Note that l is the length of the line, and, $\lambda = \alpha + j\beta$)

$$Z_0 = \sqrt{\frac{B}{C}} \quad (12)$$

$$\lambda l = \text{Cosh}^{-1}(A) \quad (13)$$

Part II:

1. Open circuit the receiving end
2. Adjust the sending- end voltage to 220 V. Note the receiving - end voltage.
3. The receiving end voltage is greater than sending end due to Ferranti effect

Part III:

1. Connect power analyzers. Switch on Load switch
2. Adjust the loading resistor to take a power of 200, 300 and 400 W respectively.
3. For each value of power, adjust C (or L) of the compensation unit to make $V_r = 220$ V
4. For each value of power, determine $+Q_r$, the reactive power to obtain the condition $V_r = V_s = 220$ V
5. Plot the results in the P-Q plane.

Calculations

ABCD parameters

(i) Open circuit test

Open circuit voltage $V_{oc} = 220$

Open circuit current $I_{oc} = 0.3$

Open circuit power $P_{oc} = 0.28$

$Z_{oc} = V_{oc}/I_{oc}$

$= 733.3333 \Omega$

$\cos \theta = W_s/(V_{oc} I_{oc})$

$$\Theta = \cos^{-1} (W_s / (V_{oc} I_{oc}))$$

$$= 64.8973 \text{ degrees}$$

$$Z_{oc} = Z_{oc} \angle \Theta$$

$$= 733.3 \angle 64.89$$

$$= -348.12 + 645.4i$$

(ii) Short circuit test:

$$\text{Short circuit voltage } V_{sc} = 192.4$$

$$\text{Short circuit current } I_{sc} = 4.60$$

$$\text{Short circuit power } P_{sc} = 0.254$$

$$Z_{sc} = V_{sc} / I_{sc}$$

$$= 41.8261 \Omega$$

$$\cos \theta = W_{sc} / (V_{sc} I_{sc})$$

$$\Theta = \cos^{-1} (W_s / (V_{sc} I_{sc}))$$

$$= 73.3220 \text{ degrees}$$

$$Z_{sc} = Z_{sc} \angle \Theta$$

$$= 41.8261 \angle 73.3220$$

$$= -20.2513 - 36.5965i$$

$$A =$$

$$= 0.9841 + 0.0229i$$

$$B = A \cdot Z_{sc}$$

$$= -19.0921 - 36.4799i$$

$$C = A / Z_{oc}$$

$$= -0.0006 - 0.0012i$$

$$D = A$$

$$= 0.9841 + 0.0229i$$

$$\text{Surge impedance } Z_0 = \sqrt{\frac{B}{C}}$$

$$= 175.13e^{-0.94528i}$$

$$\text{Propagation constant } \lambda l = \text{Cosh}^{-1}(A)$$

$$= 0.1101 + 0.2091i$$

Ferranti effect

Line Capacitance	Sending end Voltage	Receiving end Voltage
$6 \times 1 \mu\text{F} = 6 \mu\text{F}$	0	5

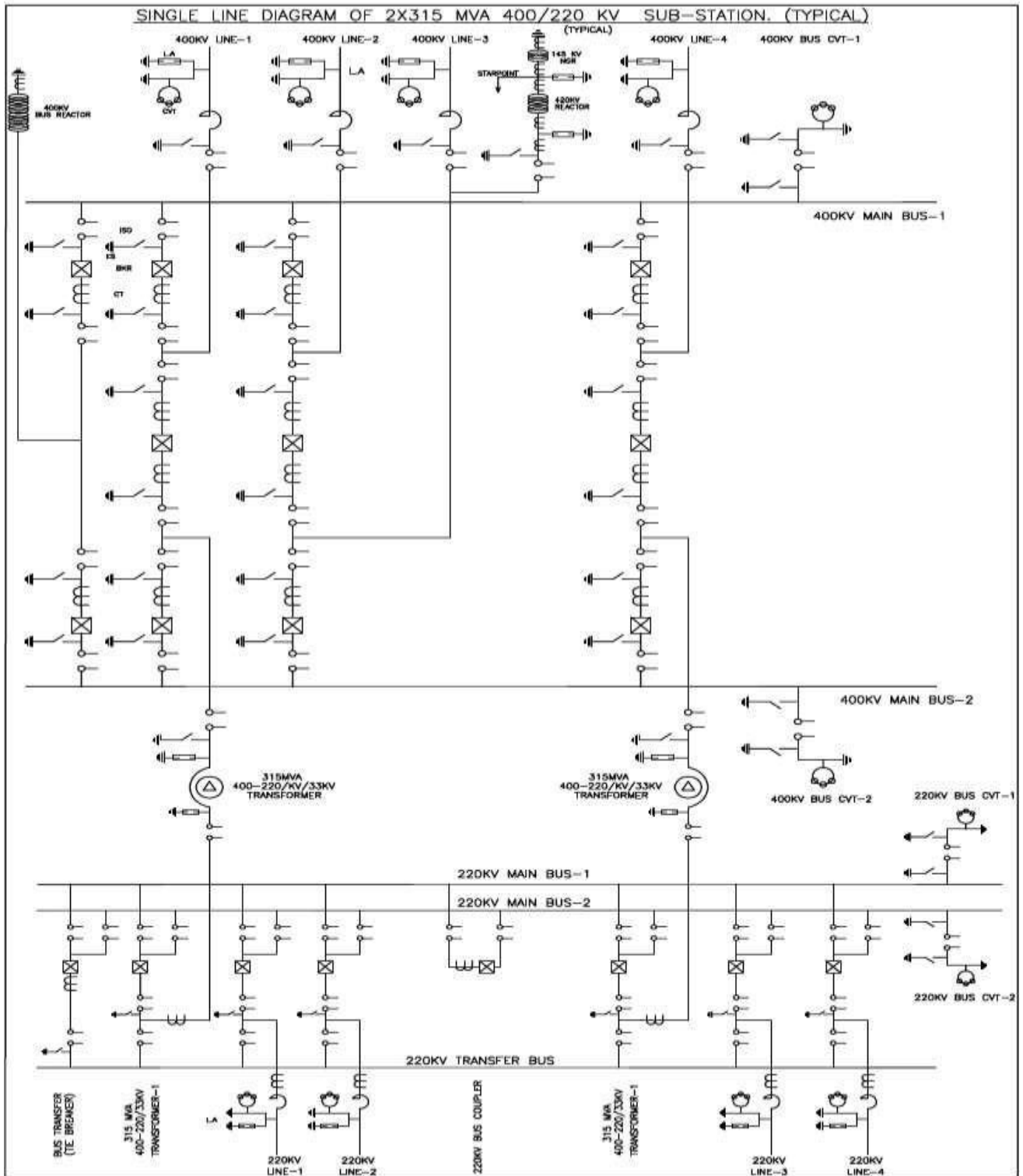

Precaution:

1. Transformer oil should be free from moisture content.
2. Nobody should go near the H.T. bushing when the test being conducted.
3. The equipment must be grounded firmly.
4. The electrodes must be cleaned properly before and after the use.
5. Do not touch the equipment without grounding it with the grounding rod.

Result:

EXPERIMENT NO.8

OBJECT:-Study the capacitance and dielectric loss of an insulating material using Schering bridge.

THORY:-

HIGH VOLTAGE SCHERING BRIDGE:-

The bridge is widely used for capacity and dielectric loss measurement of all kinds of capacitances, for instance cables, insulators and liquid insulating materials. We know that most of the high voltage equipments have low capacitance and low loss factor. This bridge is then more suitable for measurement of such small capacitance equipments as the bridge uses either high voltage or high frequency supply. If a measurement for such low capacity equipments is carried out at low voltage, the results so obtained are not accurate.

Fig. shows a high voltage Schering bridge where the specimen has been represented by a parallel combination of R_p and C_p .

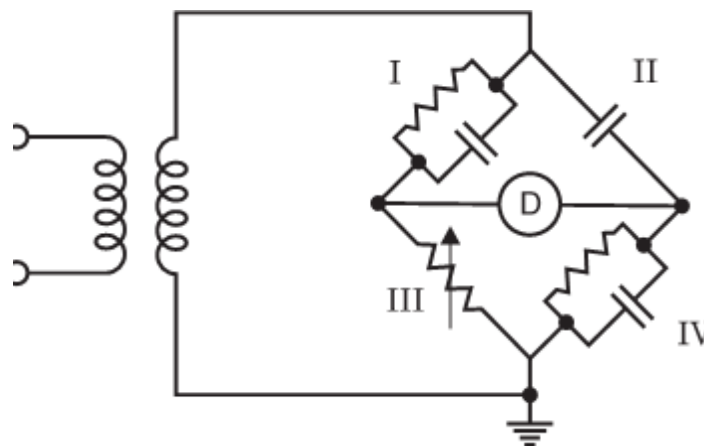

Fig. Basic high voltage schering bridge

The special features of the bridge are:

1. High voltage supply, consists of a high voltage transformer with regulation, protective circuitry and special screening. The input voltage is 220 volt and output continuously variable between 0 and 10 kV. The maximum current is 100 mA and it is of 1 kVA capacity.
2. Screened standard capacitor C_s of $100 \text{ pF} \pm 5\%$, 10 kV max and dissipation factor $\tan \delta = 10^{-5}$. It is a gas-filled capacitor having negligible loss factor over a wide range of frequency.

3. The impedances of arms I and II are very large and, therefore, current drawn by these arms is small from the source and a sensitive detector is required for obtaining balance. Also, since the impedance of arm I and II are very large as compared to III and IV, the detector and the impedances in arm III and IV are at a potential of only a few volts (10 to 20 volts) above earth even when the supply voltage is 10 kV, except of course, in case of breakdown of one of the capacitors of arm I or II in which case the potential will be that of supply voltage. Spark gaps are, therefore, provided to spark over whenever the voltage across arm III or IV exceeds 100 volt so as to provide personnel safety and safety for the null detector.

4. Null Detector: An oscilloscope is used as a null detector. The γ -plates are supplied with the bridge voltage V_{ab} and the x-plates with the supply voltage V . If V_{ab} has phase difference with respect to V , an ellipse will appear on the screen (Fig. 6.6). However, if magnitude balance is not reached, an inclined straight line will be observed on the screen. The information about the phase is obtained from the area of the ellipse and the one about the magnitude from the inclination angle. Fig. 6.6a shows that both magnitude and phase are balanced and this represents the null point condition. Fig. (6.6c) and (d) shows that only phase and amplitude respectively are balanced.

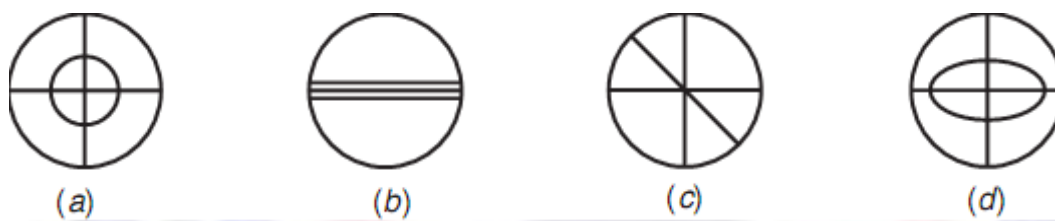

The handling of bridge keys allows to meet directly both the phase and the magnitude conditions in a single attempt. A time consuming iterative procedure being used earlier is thus avoided and also with this a very high order of accuracy in the measurement is achieved. The high accuracy is obtained as these null oscilloscopes are equipped with a γ – amplifier of automatically controlled gain. If the impedances are far away from the balance point, the whole screen is used. For nearly obtained balance, it is still almost fully used. As V_{ab} becomes smaller, by approaching the balance point, the gain increases automatically only for deviations very close to balance, the ellipse area shrinks to a horizontal line.

5. Automatic Guard Potential Regulator: While measuring capacitance and loss factors using a.c. bridges, the detrimental stray capacitances between bridge junctions and the ground adversely affect the measurements and are the source of error. Therefore, arrangements should be made to shield the

measuring system so that these stray capacitances are neutralized, balanced or eliminated by precise and rigorous calculations. Fig. 6.7 shows various stray capacitances associated with High Voltage Schering Bridge.

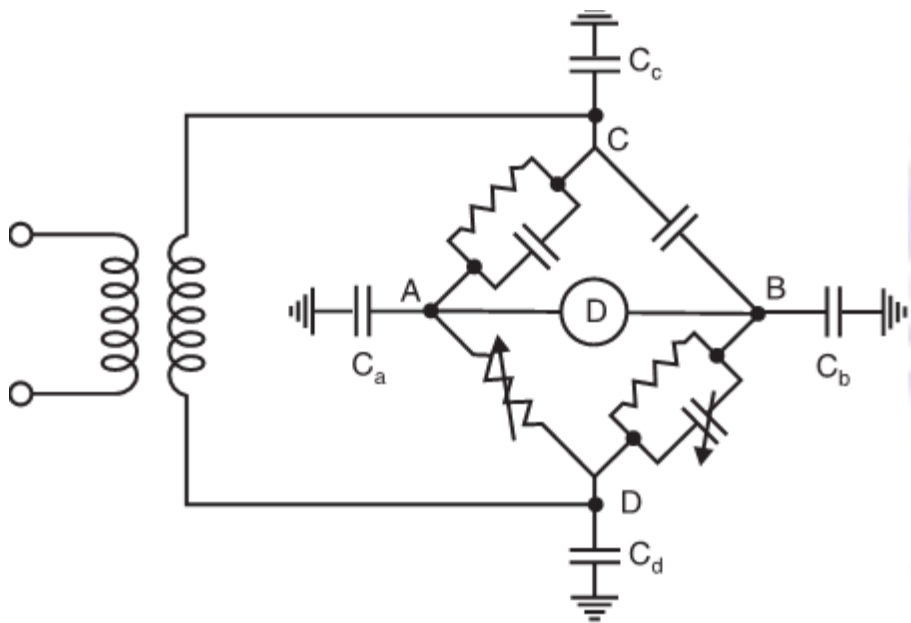

Fig. 6.7 Schering bridge with stray capacitances

C_a , C_b , C_c and C_d are the stray capacitances at the junctions A, B, C and D of the bridge. If point D is earthed during measurement capacitance C_d is thus eliminated. Since C_c comes across the power supply for earthed bridge, has no influence on the measurement. The effect of other stray capacitances C_a and C_b can be eliminated by use of auxiliary arms, either guard potential regulator or auxiliary branch as suggested by Wagner. Fig. 6.8 shows the basic principle of Wagner earth to eliminate the effect of stray capacitances C_a and C_b .

In this arrangement an additional arm Z is connected between the low voltage terminal of the four Arm Bridge and earth. The stray capacitance C between the high voltage terminal of the bridge and the grounded shield and the impedance Z together constitute a six arm bridge and a double balancing procedure is required.

Switch S is first connected to the bridge point b and balance is obtained. At this point a and b are at the same potential but not necessarily at the ground potential. Switch S is now connected to point C and by adjusting impedance Z balance is again obtained. Under this condition point 'a' must be at the same potential as earth although it is not permanently at earth potential. Switch S is again

connected to point b and balance is obtained by adjusting bridge parameters. The procedure is repeated till all the three points a, b and c are at the earth potential and thus C_a and C_b are eliminated.

MEASUREMENT OF LARGE CAPACITANCE

In order to measure a large capacitance, the resistance R_1 should be able to carry large value of

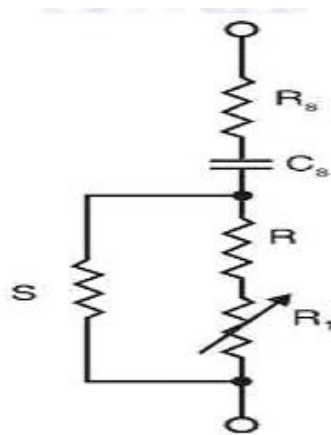

Fig. 6.12 Shunt arrangement for measurement of large capacitance

$$C_s = C'_s \frac{R_2}{R_1}$$

But here R_1 is to be replaced by the equivalent of $(R + R_1) \parallel S$.

$$\text{or} \quad \frac{(R + R_1) S}{R + R_1 + S}$$

$$\text{or} \quad \frac{1}{R_{eq}} = \frac{R + R_1 + S}{(R + R_1) S}$$

Therefore,
$$C_s = C_s' R_2 \cdot \frac{R + R_1 + S}{(R + R_1)S} \cdot \frac{R_1}{R_1} = C_s' \frac{R_2}{R_1} \cdot \frac{R_1 (R + R_1 + S)}{(R + R_1)S}$$

usually $R \ll R_1$

Therefore
$$C_s = C_s' \frac{R_2}{R_1} \frac{R_1 (R + R_1 + S)}{R_1 S} = C_s' \frac{R_2}{R_1} \left[\frac{R}{S} + \frac{R_1}{S} + 1 \right]$$

and
$$\tan \delta = \omega C_s' R_2 \cdot R/R_1$$

If circuit elements of Schering bridge are suitably designed, the bridge principle can be used upto 100 kHz of frequency. However, common Schering Bridge can be used upto about 10 kHz only.

DIELECTRIC LOSS AND EQUIVALENT CIRCUIT

In case of time varying electric fields, the current density J_c using Amperes law is given by

$$J_c = \sigma E + \frac{\partial D}{\partial t} = \sigma E + \epsilon \frac{\partial E}{\partial t}$$

$$\begin{aligned} E &= E_m e^{j\omega t} \\ \frac{\partial E}{\partial t} &= jE_m \omega e^{j\omega t} = j \omega E \\ \text{Therefore, } J_c &= \sigma E + j \omega \epsilon E \\ &= (\sigma + j \omega \epsilon) E \end{aligned}$$

For harmonically varying fields

In general, in addition to conduction losses, ionization and polarization losses also occur and, therefore, the dielectric constant $\epsilon = \epsilon_0 \epsilon_r$ is no longer a real quantity rather it is a complex quantity. By definition, the dissipation factor $\tan \delta$ is the ratio of real component of current I_ω to the reactive component I_r

$$\tan \delta = \frac{I_\omega}{I_r} = \frac{P_{\text{diss}}}{P_r}$$

Here δ is the angle between the reactive component of current and the total current flowing through the dielectric at fundamental frequency. When δ is very small $\tan \delta = \delta$ when δ is expressed in

radians and $\tan \delta = \sin \delta = \sin (90 - \phi) = \cos \phi$ i.e., $\tan \delta$ then equals the power factor of the dielectric material.

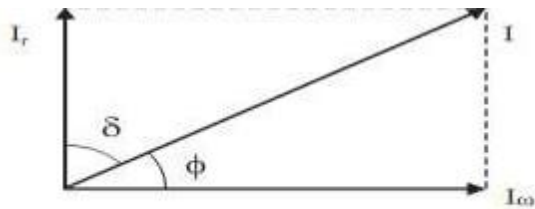

Fig. 6.3 Phasor diagram for a real dielectric material

As mentioned earlier, the dielectric loss consists of three components corresponding to the three loss mechanism.

$$P_{\text{diel}} = P_c + P_p + P_r$$

$$P_{\text{diel}} = P_c = \sigma E^2 A d = V^2 \omega C \tan \delta = \frac{V^2 \omega \epsilon_0 \epsilon_r A}{d} \tan \delta$$

$$\text{or} \quad \sigma E^2 = \frac{V^2}{d^2} \omega \epsilon_0 \epsilon_r \tan \delta = E^2 \omega \epsilon_0 \epsilon_r \tan \delta$$

$$\text{or} \quad \tan \delta = \frac{\sigma}{\omega \epsilon_0 \epsilon_r}$$

In order to include all losses, it is customary to refer the existence of a loss current in addition to the charging current by introducing complex permittivity.

$$\epsilon^* = \epsilon' - j \epsilon''$$

and the total current I is expressed as

$$I = (j \omega \epsilon' + \omega \epsilon'') \frac{C_0}{\epsilon_0} V$$

where C_0 is the capacitance without dielectric material.

For the parallel circuit the dissipation factor is given by

$$\tan \delta = \frac{1}{\omega C_p R_p}$$

and for the series circuit

$$\tan \delta = \omega C_s R_s$$

For a fixed frequency, both the equivalents hold good and one can be obtained from the other. However, the frequency dependence is just the opposite in the two cases and this shows the limited validity of these equivalent circuits.

The information obtained from the measurement of $\tan \delta$ and complex permittivity is an indication of the quality of the insulating material.

- (i) If $\tan \delta$ varies and changes abruptly with the application of high voltage, it shows inception of internal partial discharge.
- (ii) The effect to frequency on the dielectric properties can be studied and the band of frequencies where dispersion occurs i.e., where that permittivity reduces with rise in frequency can be obtained.

Precaution:-

Result:-

